

HYDROLOGICAL SERVICES PTY LTD

QUALITY SYSTEM
ISO
9001
2000
CERTIFIED

INSTRUCTION MANUAL
UNIVERSAL CURRENT METER
MODEL OSS-B1

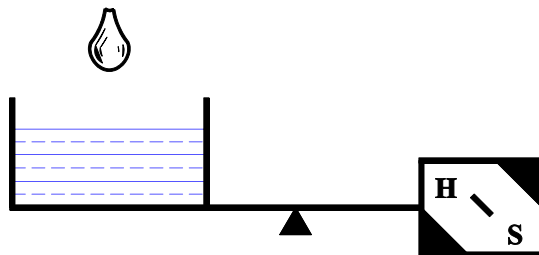

HYDROLOGICAL SERVICES PTY LTD
PO BOX 332, LIVERPOOL B.C NSW 1871, AUSTRALIA
Phone: (Int.) 612 9601 2022 Fax:(Int.) 612 9602 6971
Phone: (Nat.) (02) 9601 2022 Fax:(Nat.) (02) 9602 6971
Email: sales@hydrologicalservices.com

HYDROLOGICAL SERVICES PTY LTD

CONTENTS

I	HYDROLOGICAL SERVICES STANDARD WARRANTY TERMS	CMB 100-04
II	GENERAL	CMB 100-05
III	UNPACKING YOUR OSS-B1 CURRENT METER	CMB 100-06
IV	OPERATION	CMB 100-07
V	SPECIFICATION	CMB 100-010
VI	MAINTENANCE	CMB 100-011
	<i>Section 1: Prior to discharge measurements</i>	CMB 100-011
	<i>Section 2: During and after Discharge</i>	CMB 100-012
	Section 3: Tips for Easy Maintenance	CMB 100-013
VIII	FAULT FINDING	CMB 100-014
	<i>Mechanical Fault Finding</i>	CMB 100-014
	<i>Electrical Fault Finding</i>	CMB 100-015
	<u>Closed Circuit Fault</u>	CMB 100-015
	<u>Open Circuit Fault</u>	CMB 100-016
XI	REPLACE OF CABLE ENDS	CMB 100-017
	<i><u>Impulse Counter End and Complete Repair</u></i>	CMB 100-017
	<i><u>Current Meter Ends and Complete Repair</u></i>	CMB 100-018
X	PARTS LIST	CMB 110-01
XI	ACCESSORIES	CMB 110-08

HYDROLOGICAL SERVICES PTY LTD

UNIVERSAL WADING RODS [CMB 110-08](#)

RELOCATING DEVICE ASSEMBLIES [CMB 110-08](#)

GAUGING ROD STAND [CMB 110-09](#)

HYDROLOGICAL SERVICES PTY LTD

I HYDROLOGICAL SERVICES STANDARD WARRANTY TERMS

WARRANTY, DISCLAIMER AND LIMITATION OF LIABILITY:

We warrant this product to be free from defects in material and workmanship for a period of three years from the date of shipment hereof or its total rated life, whichever first occurs. During the warranty period, we will repair or replace this product if it is returned to us with shipping charges prepaid and we determine it to be defective. This warranty shall not apply if this product has been subjected to misuse, negligence, accidents, or misapplied, or modified or repaired by unauthorised persons, or improperly installed, and we shall not be liable to any person for personal injury or property damage caused by such a product.

All other warranties, express and implied, including warranties of MERCHANTABILITY and FITNESS FOR A PARTICULAR PURPOSE, are disclaimed. All other remedies and liabilities, including incidental, consequential, and special damages, losses, and expenses, are excluded.

Note: It is Hydrological Services' policy to support all of our products. If design or workmanship problems arise after this statutory warranty period we request that you contact us.

HYDROLOGICAL SERVICES PTY LTD

OSS-B1 CURRENT METER MODEL OSS-B1

II GENERAL

The Hydrological OSS-B1 Current Meter is a world recognised design instrument for measuring the velocity of water in shallow natural water courses, rivers, canals, and pipe line. The OSS-B1 provides solutions for all velocity measuring applications.

One of the great features of the OSS-B1 is it can be used with 20 mm diameter wading rod and relocating device, streamlined suspension tube, portable winches and permanent cableway installations, with streamlined or ground feeling weights. A tail fin assembly is provided to control directional stability during suspended measurements.

The OSS-B1 comes with lots of accessories which enable the user to endure water flow measurement easily and accurately.

All current meters manufactured by Hydrological Services are calibrated in our purpose built high velocity rating tank prior to shipment. This rating tank is considered as best in the world since it can run at a velocity of 0.005 m/s minimum and 8 m/s maximum with a velocity resolution of +/- 0.001mm

As part of our service we are able to recondition and recalibrate current meters of any make, including electro magnetic and other solid state meters. Calibration is directly traceable to International Standards.

All current meters are calibrated in accordance with **AS 3778.6.3-1992**. This standard is identical with and has been reproduced from **ISO 3455:1976**.

The purpose of this manual is to make the user familiar with the OSS-B1 current meter. It is a sensitive and reliable precision instrument. It is advisable to read this manual carefully and fully understand its use. After reading this manual if you are not sure about any details, please do not hesitate to contact our office (contact details are on the cover of this manual).

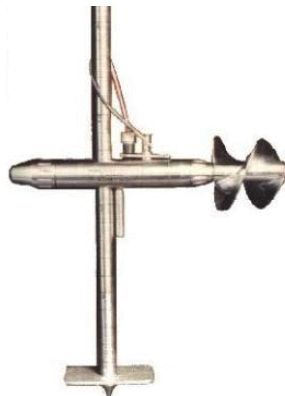

HYDROLOGICAL SERVICES PTY LTD

III UNPACKING YOUR OSS-B1 CURRENT METER

This package should contain:

- C OSS-B1 Body
- C OSS-B1 Lead
- C Body Key
- C Fan type A (Fan type 1,2 and 4 are accessories)
- C 3 wading rods (1.00m,2.00m,3.00m)
- C CMC20/200 counter
- C 2 spare bearings
- C 1 reed switch
- C Screwdriver (Short)
- C Screwdriver (Small)
- C O’rings for (fan carrier-1, reed switch cover -2, lead-1, terminal post-1)
- C Post ground
- C 1 oil bottle
- C Rating Tables
- C CMC20/200 manual
- C This manual

Note: Tail Fin Stem Assembly and other accessories are supplied on request.

HYDROLOGICAL SERVICES PTY LTD

IV OPERATION

One impulse signal is produced per Fan revolution. As shown in figure 1 below, this signal is generated by an encapsulated reed switch (1) which resides inside the meter body (2) and a permanent magnet (3) set into the rotating Fan assembly. A cover sealed with two O-rings provides a water-tight housing for the reed switch, while gold plated contact pins ensure low-resistance signal passage.

The voltage must not exceed 9V DC. Provided the impulse counters have spark-suppression circuits, the meter can be loaded with up to 1.6 watts. All our counters meet these requirements (refer to specification).

Four type of stainless steel Fans (4) can be used with this meter, all these Fans are supported on bearings which run within the oil filled hub of the Fan assembly. The capillary oil passage between the stainless steel axle (5) and Fan carrier (6), prevents entry of water to the bearings. A locknut on the shaft locates the bearings and sets the end float of the assembly.

HYDROLOGICAL SERVICES PTY LTD

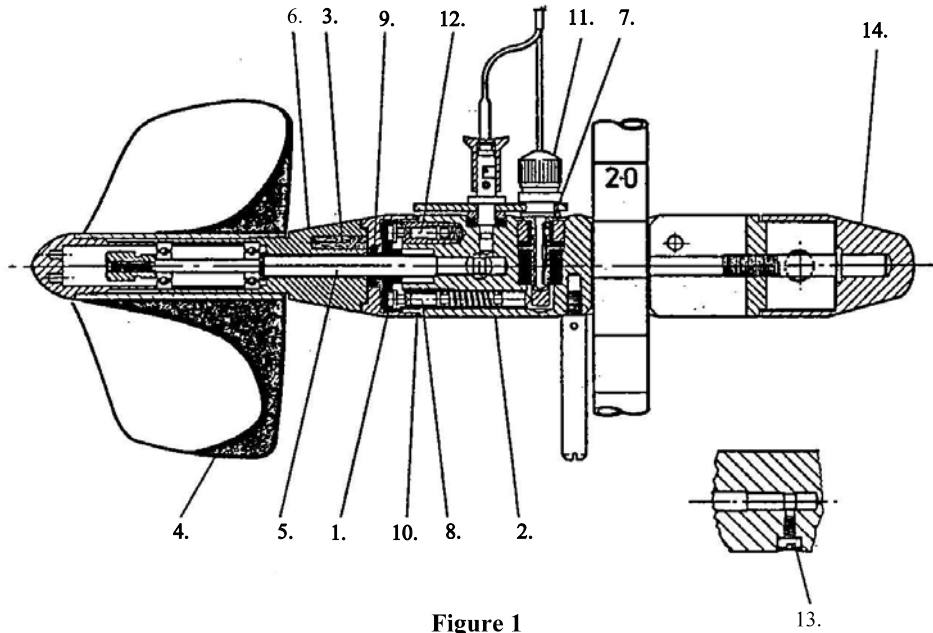

Figure 1

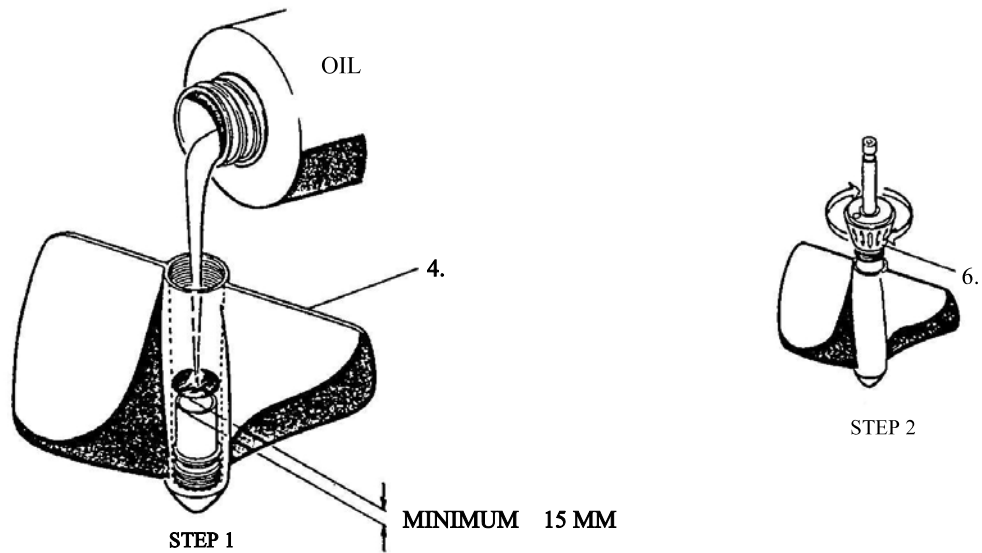

Figure 2

HYDROLOGICAL SERVICES PTY LTD

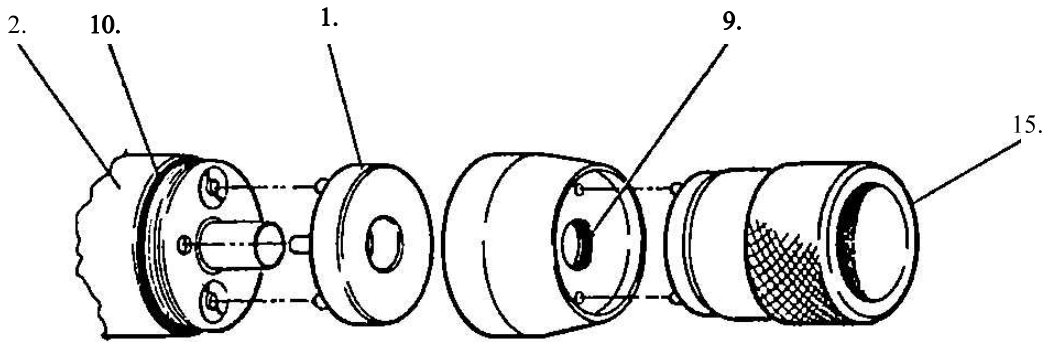

Figure 3

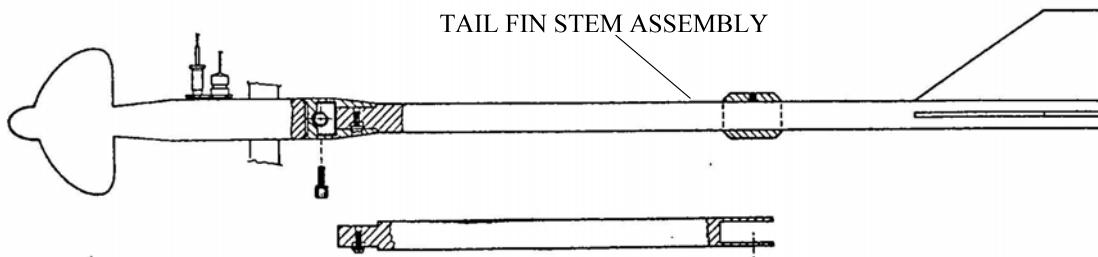

Figure 4

HYDROLOGICAL SERVICES PTY LTD

V SPECIFICATION

Switch Encapsulated reed single contact per revolution, maximum volts 9V DC
maximum power 1.6 Watts.(if spark suppression in counter).

Fans Stainless Steel

Fan No.	Description	Starting Velocity m/s	Range of Component Effect	Maximum Velocity m/s
A	100mm Dia. 0.125 m pitch	0.025	±45°	5.0
1	125mm Dia. 0.25 m pitch	0.025	±5°	10.0
2	125mm Dia. 0.50 m pitch	0.040	±5°	10.0
4	80mm Dia. 0.25 m pitch	0.035	±5°	5.0

Mounting - 20mm diameter wading rods with clamp
 - Streamlined suspension tube with adaptor
 - Hanger bar

HYDROLOGICAL SERVICES PTY LTD

VI MAINTENANCE

The maintenance of the OSS-B1 current meter can be divided in three sections as stated below.

Section 1: Prior to discharge measurements

Initial set up

- Open the case and pick up the Fan assembly
- Undo the fan carrier
- Remove fan carrier and shaft assembly (do not put it down anywhere it may attract dirt particles)
- hold the fan upright and $\frac{3}{4}$ filling as shown in figure...
- Replace the oil bottle cap
- Replace axle and fan carrier, excess oil will be forced up through the capillary gap around the axle, ensure fan carrier is tightened
- Wipe the excess oil of the meter using lint free paper towel
- Do not forget to close the oil bottle straight after usage to avoid contamination of the oil
- Slide the fan assembly into the body and use the stubby screwdriver to tighten the retaining screw to lock the fan assembly in place
- Prior to spin test hold the current meter in the horizontal position and spin by hand for approx. one minute to get rid of the hydraulic pressure
- Spin test the meter against time. This is required to test the performance of the shaft and bearings
- Spin test results are dependent on the fan type and temperature (see table below)

HYDROLOGICAL SERVICES PTY LTD

<i>OSS-B1 Spin Test</i>	
<i>Fan No.</i>	<i>Time (sec)</i>
<i>A</i>	<i>Minimum 110 sec</i>
<i>1</i>	<i>Minimum 90 sec</i>
<i>2</i>	<i>Minimum 90 sec</i>
<i>4</i>	<i>Minimum 90 sec</i>

- After the spin test is performed connect your current meter to the counter using the lead, this important to test the lead, reed switch and counter.

Section 2: During and after Discharge Measurements

After every discharge measurement, or one hour of use the current meter should be cleaned and refilled with oil, if continuing a discharge measurement.

- Spin test meter
- Undo the cleaning jar cap and $\frac{3}{4}$ filling with white spirit
- Remove fan assembly from meter body by undoing the retraining screw and separating the body from the fan
- Remove fan carrier and shaft assembly (do not put it down anywhere it may attract dirt particles)
- Empty the old oil in a recycling container (do not tip oil on the ground this will pollute the environment)

- Put the shaft and bearing assembly into the cleaning jar.
- Agitate them.
- Fill up the fan with white spirit put your thumb in place of carrier and shake it really hard for a few seconds.

HYDROLOGICAL SERVICES PTY LTD

- Blow dry the shaft assembly, fan carrier and fan
- Re-assemble the fan, if discharge measurement is finished
- Wipe box clean and return the fan assembly to the case
- If continuing a discharge measurement, Refill the fan with oil as per section 1
- Spin test the current meter at per section 1
- Repeat all the above steps for every discharge measurement
- Tip the white spirit in a spare bottle

Note: Both oil and white spirit can be recycled using filter papers

Section 3: Tips for Easy Maintenance

It is advisable that the user maintain the OSS-B1 current meter at all time.

- Keep the OSS-B1 case clean
- Clean all the tools after usage
- Use lint free paper towels and white spirit (do not use methylated)
- Office service is required for the OSS-B1 current meter about once a month if it is used on a daily basis (i.e. Fully dismantle shaft assembly, fan carrier and fan; Clean each item using hot soapy water and then rinse with white spirit)
- Check the lead and new the ends connections
- If the current meter fails the spin test refer to the mechanical fault finding section for details
- Test lead, counter and reed switch (see electrical fault finding section for details)

VII SERVICE AND RECALIBRATION

HYDROLOGICAL SERVICES PTY LTD

- Recalibrate the current meter every 300 hours of use or once a year whichever ever comes first (see Hydrological Services calibration certificate for details)
- For recalibration only, send the body and the fans that require calibration (to save weight). However, if other items need repair they can be sent with the body and fans.

Note: Hydrological Services provides a recalibration and repair service for all types of current meters.

VIII FAULT FINDING

Mechanical Fault Finding

Symptom	Possible Causes	Action	Remark
Failed spin test	- Dirty or faulty bearings	- Clean Bearings and try to spin test again. If Problem persist replace bearings.	- Dirty bearings can be identified towards the end of the spin test when the fan stops suddenly.
	- Bent shaft	- If the shaft is slightly bent return to HS for repair. - If the shaft is very bent return to HS for replacement.	- Bent shaft can be identified by looking at the pointed centre of the fan during spin test. If this point is turning off-centre this indicates that the shaft is bent.

Electrical Fault Finding

HYDROLOGICAL SERVICES PTY LTD

If an electrical fault has been traced to the current meter, the following conditions should be checked using a multimeters or impulse counter.

Faults will be either CLOSED CIRCUIT or OPEN CIRCUIT, and if the CMC-200 counter is used, set the control switches to “ON” and “INT”(ie. no time limit). Spin the Fan and if the audible signal sounds continuously, the fault is a “CLOSED CIRCUIT”. If no audible signal is heard, the fault then is an “OPEN CIRCUIT”.

Closed Circuit Fault

Symptom	Possible Cause	Action
Fault occurs only when meter in water	- Water entering contact plug receptacle and earthing between plug and body	- Replace damaged plug or missing seal (see figure 7)
Circuit closed in any magnet position, but open with magnet removed	- Reed switch failed	- Replace reed switch assembly (Figure 3)
Circuit closed without magnet in position	- Reed switch damaged - Water damaged during handling allowing contacts to earth onto meter body	- Replace reed switch assembly - Remove reed switch (Figure 3 No.1) and insulated contact assembly (Figure 3 No 8). Drain or wipe away water. Flush with alcohol or methyl. Spirits, then air dry. Apply silicone grease to contact surfaces and thread on insulating sleeve before replacing. Check damaged O-rings (Figure 3 No 9 and10) replace. Apply silicon grease before fitting. - Check for damage to spigot through reed switch assembly. Return to factory for repairs.

Open Circuit Fault

HYDROLOGICAL SERVICES PTY LTD

Symptom	Possible Cause	Action
Open circuit between plug (11) and insulated reed switch contact (8)	<ul style="list-style-type: none">- Faulty plug contact- Faulty insulated contact assembly (8)	<ul style="list-style-type: none">- Check fit of plug in hole- Remove, wipe surface clean and check spring compression. Re-assemble with silicone grease on all surfaces.
No closure of reed switch contact when magnet in position.	<ul style="list-style-type: none">- Damaged Reed Switch Assy.	<ul style="list-style-type: none">- Replace
Reed switch operating but signal not passing to body.	<ul style="list-style-type: none">- Faulty earth contact (12)	<ul style="list-style-type: none">- Check spring compression. Remove assembly and wipe clean contact surfaces with silicon grease and re-assemble.

XI REPLACE OF CABLE ENDS

HYDROLOGICAL SERVICES PTY LTD

Impulse Counter End and Complete Repair

1. Strip back 140 mm of main cable insulation (1) after shortening to new length.
2. Expose 5 mm of conductor (2) and twist strands tightly, then solder.
3. Slide on heat shrink sleeve (3), red and black identifying sleeves (4) and plug covers (5).
4. Push soldered conductors into plugs (6) and lock with grub screws (7).
5. Bring cover forward over plugs.
6. Position heat shrink sleeve centrally over grey cable insulation and fix in place

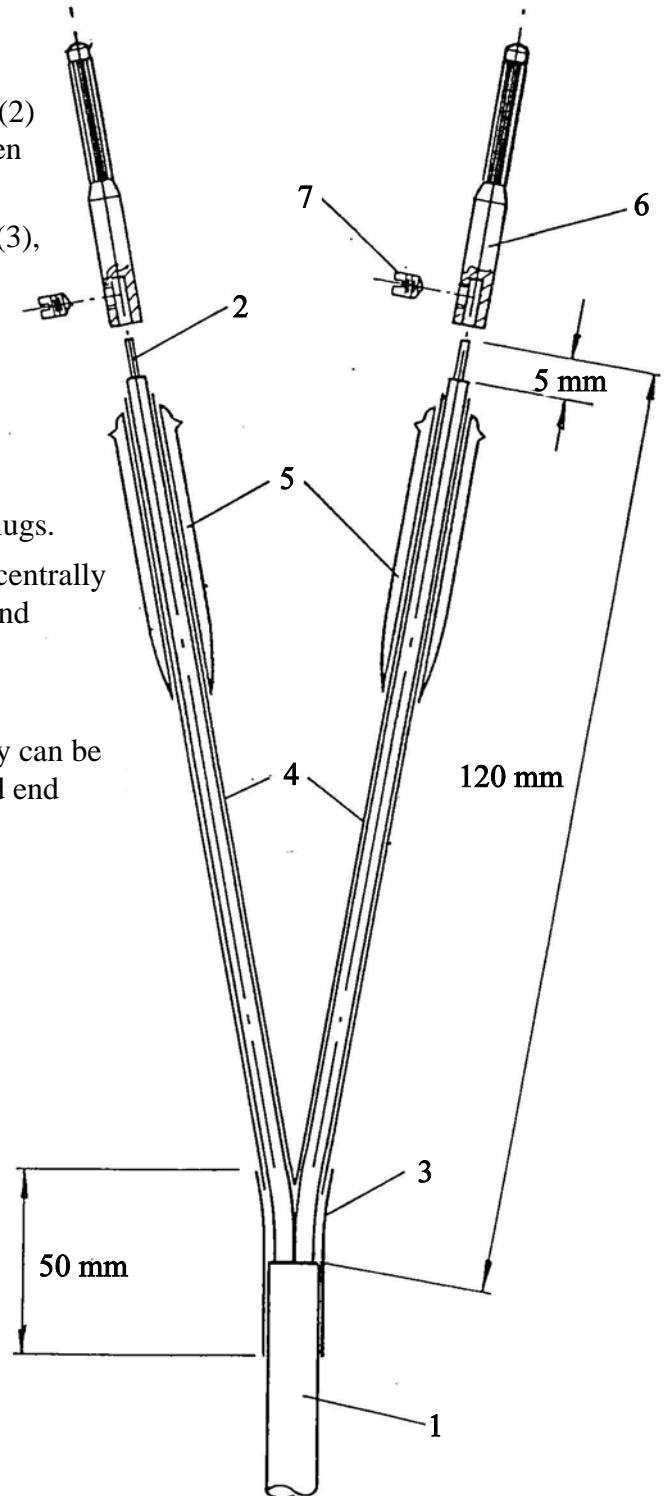

NOTE: Repair to either plug end individually can be made also, by only cutting away the damaged end and following steps 2, 4 & 5.

Figure 5

HYDROLOGICAL SERVICES PTY LTD

Current Meter Ends and Complete Repair

1. Shorten cable (1) to new length and strip outer insulation (2) to 140mm (red plug end) and 120mm (black plug end).
2. Expose 5mm of conductors (3) and twist strands tightly, then solder.
3. Slide on heat shrink sleeve (4) red (5), and black (6) identifying sleeves.
4. On the positive (+) end, push plug cap (7), washer (8), rubber bush (9) and plug holder (10) over cable.
5. Lock conductor into plug pin (11), then slide back into plug holder and screw plug cap into place.
6. Fit rubber seal (12) to plug pin.
7. For the negative (-) end, slide on black heat shrink tube (13). Push conductor into the earth pin (14) and solder in place. Bring heat shrink sleeve forward onto earth pin and fix down with heat.
8. Fix down heat shrink sleeve (4) over main cable termination.

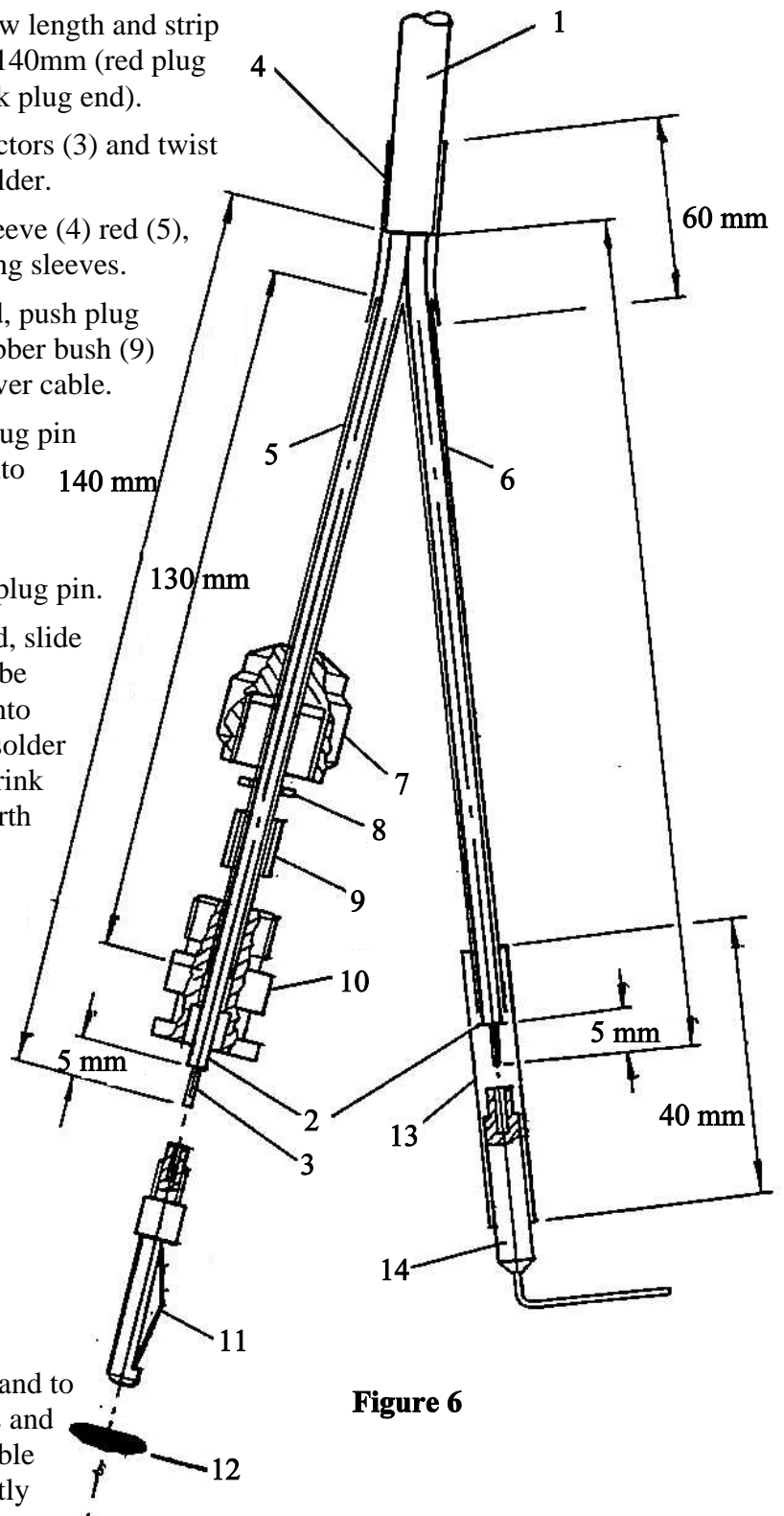

Figure 6

Repairs can be made individually to the positive (+) end with steps 2, 4, 5, and 6 and to the negative (-) end, by following steps 2 and 7. However, the shortened ends of the cable might be difficult to assemble conveniently

HYDROLOGICAL SERVICES PTY LTD

onto the current meter, and it is usually preferable to reconstruct the cable as detailed in figure 6.

X PARTS LIST

HYDROLOGICAL SERVICES PTY LTD

	ITEM	PART NO.	QTY
1	Fan 80 Dia. X 0.125 P	CBM01-01	1
2	Fan 125 Dia. X 0.5 P	CMB01-02	1
3	Fan 100 Dia. X 0.125 P	CMB01-03	1
4	Fan 125 Dia. X 0.25 P	CMB21-01	1
5	O-Ring	SC024-12	1
6	Fan Carrier	CMB02-01	1
7	Magnet	SC096-01	1
8	Axle	CMB02-02	1
9	Bearing	SC058-12	2
10	Spacer	CMB02-03	1
11	Spacer Oil	CMB02-05	1
12	Locknut	CMB02-04	1
13	Body	CMB03-01	1
14	O-Ring	SC024-11	1
15	O-Ring	SC024-09	1
16	Contact Cover	CMB03-02	1
17	Clamp Head	CMB03-03	1
18	Clamp Stem	CMB03-04	1
19	Ground Post (80 Dia. Fan)	CMB03-05	1
20	Ground Post (125 Dia. Fan)	CMB03-06	1
21	Retaining Screw - Axle	CMB03-07	1
22	Retaining Screw - Terminal Post	CMB03-08	1
23	Pivot Pin	CMB03-09	1
24	Retainer - Pivot Pin	CMB03-10	1
25	Reed Switch Assembly	SC006-15	1
26	Housing - Reed Switch	CMB04-01	1

HYDROLOGICAL SERVICES PTY LTD

27	Contact Pin	CMB04-02	2
28	Aligning Pin	CMB04-03	1
29	Contact Pin - Front	CMB05-01	2
30	Contact Spring - Long	CMB05-02	1
31	Contact Pin - Rear	CMB05-03	1
32	Insulating Sleeve	CMB05-04	1
33	Earth Contact Sleeve	CMB06-01	1
34	O-Ring	SC024-08	1
35	Contact Spring - Short	CMB06-02	1
36	Collar	CMB07-01	1
37	Insulating Sleeve - Upper	CMB07-02	1
38	Plug Socket	CMB07-03	1
39	Insulation Sleeve - Lower	CMB07-04	1
40	Terminal Post	CMB08-01	1
41	Cap	CMB08-02	1
42	Spring	CMB08-03	1
43	Pin	SC042-04	1
44	Clamp	CMB08-04	1
45	Washer	CMB08-05	1
46	Roll Pin	SC042-07	1
47	Tail Fin Stem Assembly	CMB09-01A	1
48	Stem Extension	CMB09-02	1
49	Adaptor	CMB09-04	1
50	Counterweight	CMB09-05	1
51	Socket Head Capscrew	SC045-20	1
52	Retaining Screw	SAN20-04	2
53	Grubscrew	SC039-04	1

HYDROLOGICAL SERVICES PTY LTD

54	Counter Lead Assembly 4.0M	CMB10	1
55	Counter Lead Assembly 5.0M	CMB11	1
56	Counter Lead assembly 10.0M	CMB12	1
57	Axle Cover	CMB13	1
58	Current Oil Bottle (250 ml)	CMB23	1
59	Screwdriver (Short)	SC002-06	1
60	Screwdriver (Small)	SC002-07	1
70	Spanner (Contact Cover)	CMB03-02T	1
89	Hexagon Wrench (Tail Fin Adaptor)	SC002-11	1
90	Hexagon Wrench (Streamlined Tube adaptor)	SC002-05	1
91	Hexagon Wrench (Tail Fin Counterweight)	SC002-02	1
92			
93	2 Core Grey Lead	SC031-01	1
94	Heatshrink	SC033-20	2
95	PVC Tube Black	SC033-01	2
96	Earth Pin	CMB10-01	1
97	PVC Tube Red	SC033-07	1
98	Nut	SP01-02	1
99	Flat Washer	SC065-13	1
100	Compression Sleeve	SP01-06	1
101	Pin	SP01-01	1
102	Straight Plug Body	SP01-03	1
103	O-ring	SC024-14	1
104	Bunch Plug Black	SC043-12	1
105	Bunch Plug Red	SC043-11	1

HYDROLOGICAL SERVICES PTY LTD

HYDROLOGICAL SERVICES PTY LTD

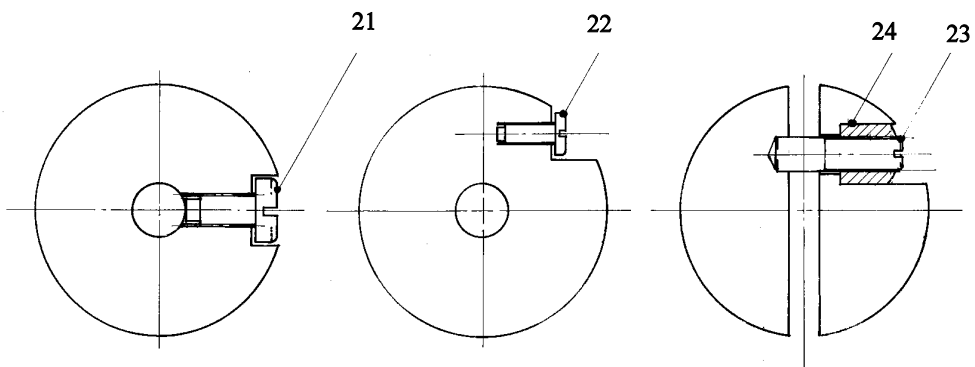
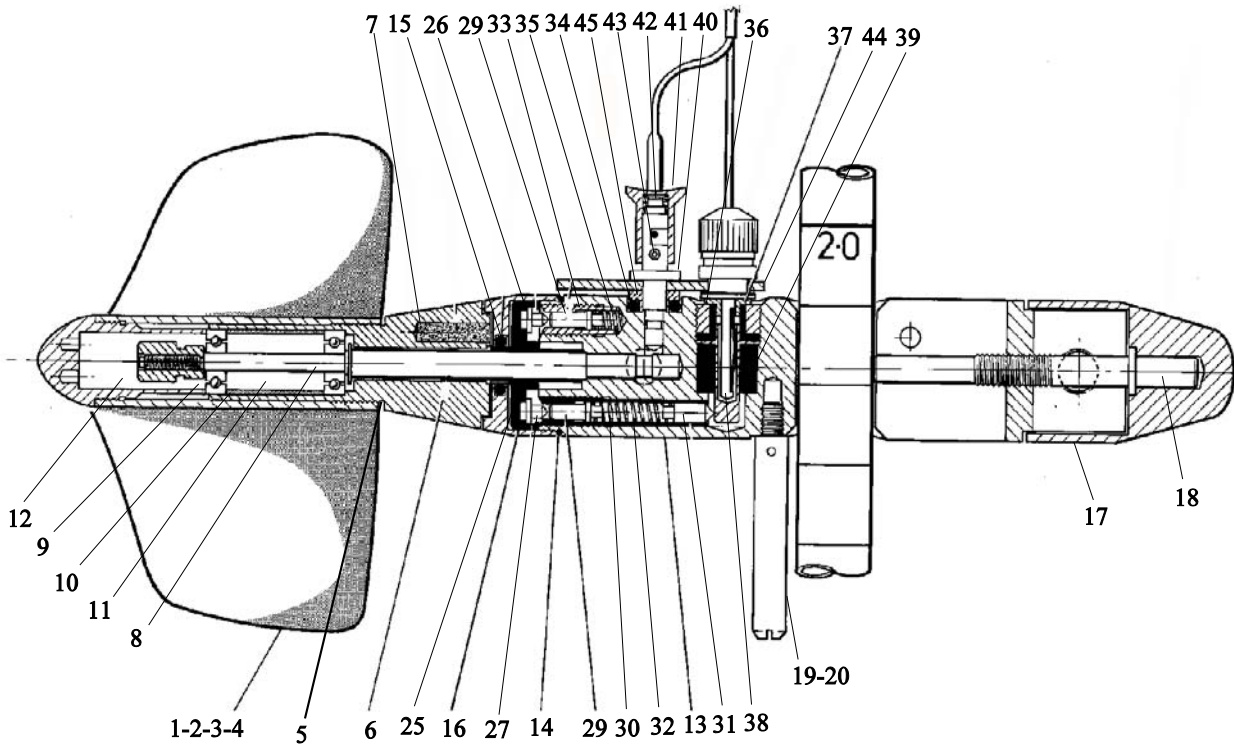

HYDROLOGICAL SERVICES PTY LTD

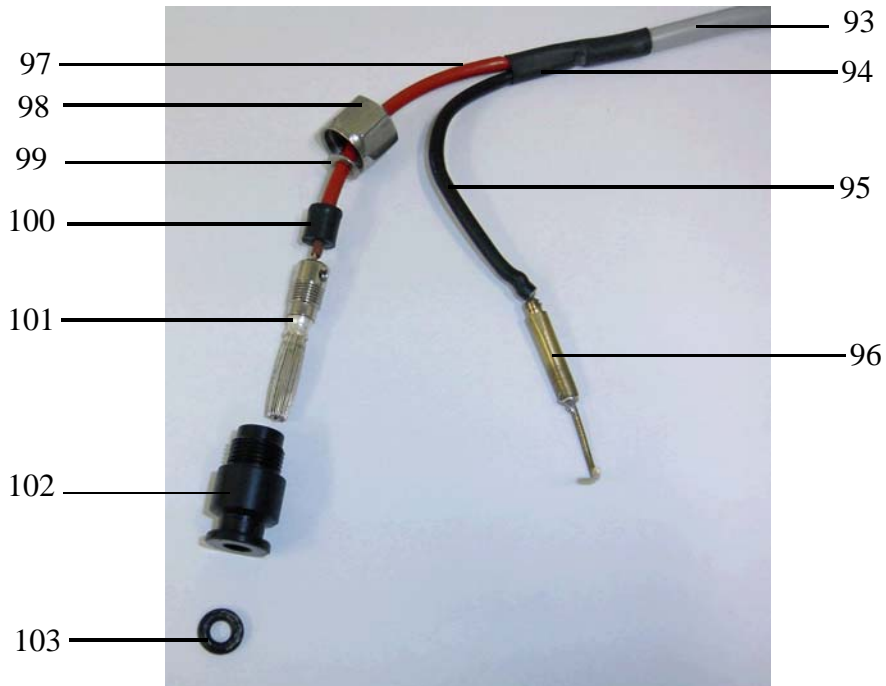

ASSEMBLY LEAD CURRENT METER END

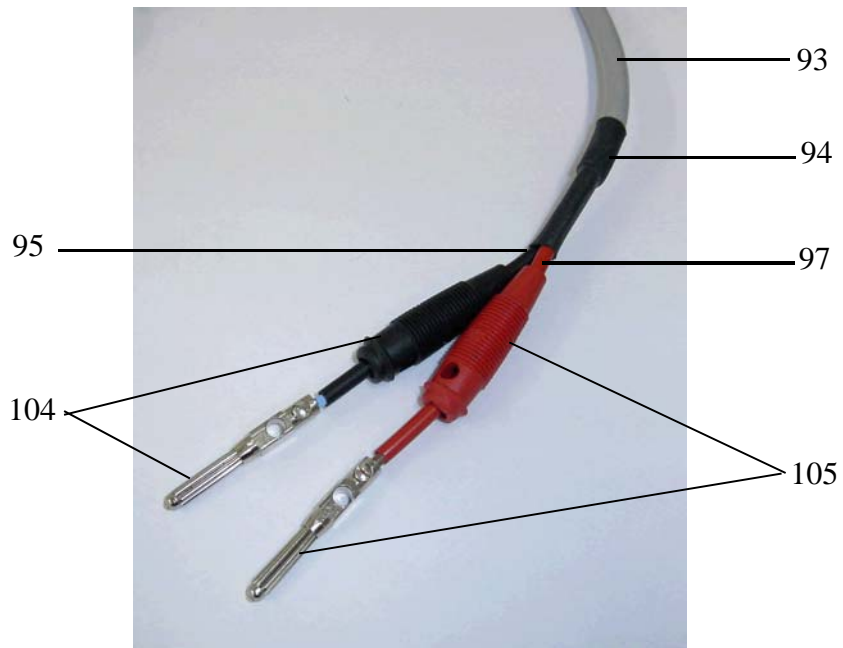

ASSEMBLY LEAD CMC COUNTER END

HYDROLOGICAL SERVICES PTY LTD

UNIVERSAL WADING ROD AND RELOCATING DEVICE.

	<u>ITEM</u>	<u>PART NO.</u>	<u>QTY</u>
	Three "W.R." series wading rod sections, plated alloy steel, graduations each 2cm and markings at decimetre (10cm) intervals. 0 - 1 metre 1 - 2 metre 2 - 3 metre	WR01 WR02 WR03	1 1 1
	Point	WR04-01	1
	Foot Plate	WR04-02	1
	Canvas Carrying Bag	WR05	1
	Fixing Screw	SAN20-04	5
	Screwdriver	SC002-06	1
METER RELOCATING DEVICE, STAINLESS STEEL, TWO X 1 METRE SECTIONS			
	Bottom Section	RD01	1
	Top Section	RD02	1
	Locking Tool	RD03	1

XI ACCESSORIES

UNIVERSAL WADING RODS

RELOCATING DEVICE ASSEMBLIES

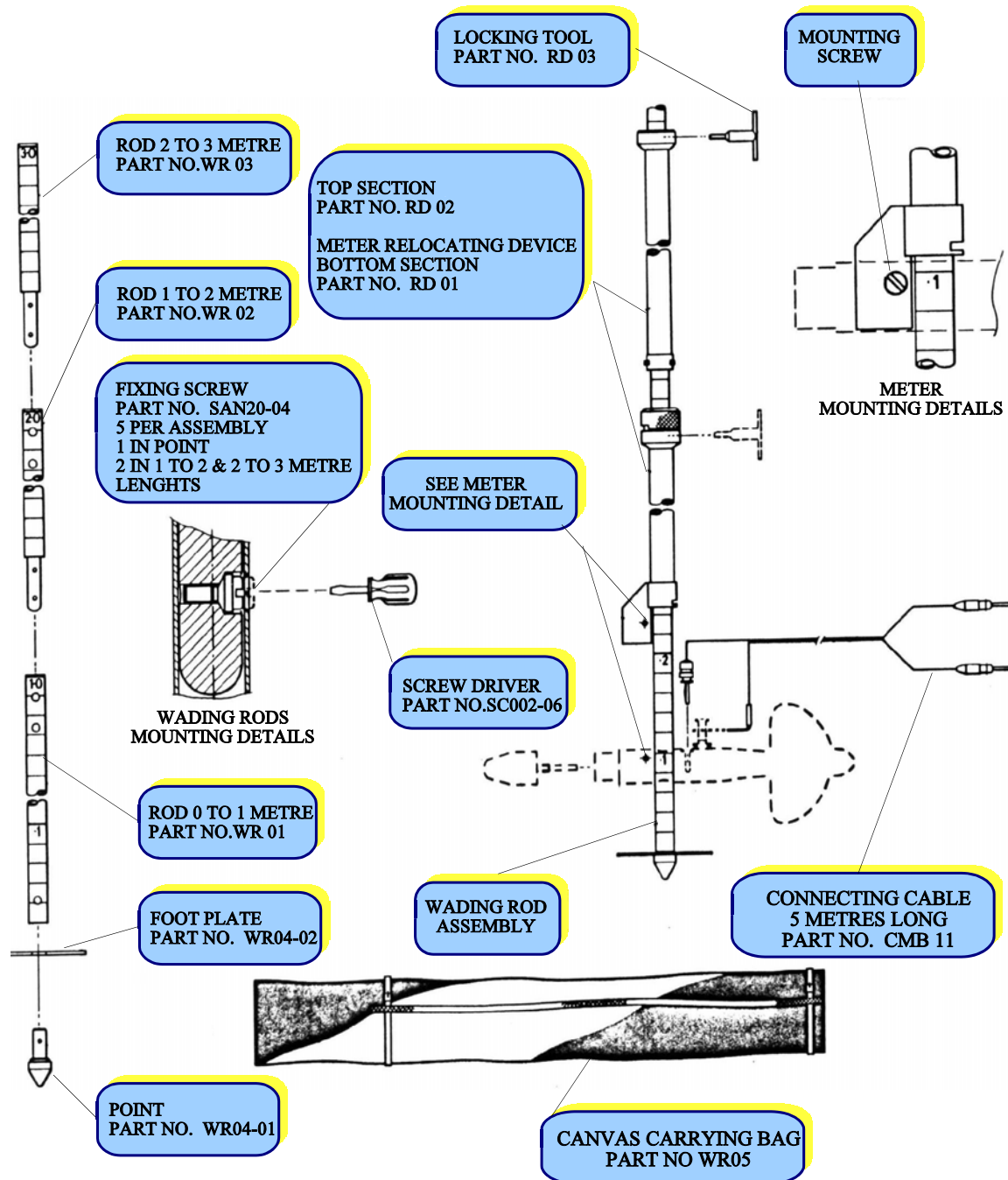

UNIVERSAL WADING ROD FOR OSS-B1 CURRENT METER
ASSEMBLY SERIES W.R

HYDROLOGICAL SERVICES PTY LTD

GAUGING ROD STAND

