

**Point Velocity Display**

**Model PVD100**

**Operation Manual**

HYDROLOGICAL SERVICES Pty Ltd  
48-50 Scrivener Street  
Liverpool NSW 2170  
Australia

Ph. 61 2 9601 2022 Fax. 61 2 9602 6971  
Internet: [www.hydrologicalservices.com](http://www.hydrologicalservices.com)  
E-Mail: [sales@hydrologicalservices.com](mailto:sales@hydrologicalservices.com)

---

---

**TABLE OF CONTENTS**

<b>1.</b>	<b>Introduction .....</b>	<b>3</b>
2.1	Overview.....	4
<b>3.</b>	<b>Installation .....</b>	<b>5</b>
3.1	Hardware Connections .....	5
<b>4.</b>	<b>Operation .....</b>	<b>6</b>
4.1	Description of Controls .....	6
4.1.1	Pushbuttons.....	6
4.1.2	Indicator LEDs .....	7
4.1.3	Factory Default Settings.....	7
4.2	The Main Display .....	8
4.3	The Menus .....	11
4.3.1	Special Operating Functions .....	11
4.3.2	Velocity / Counts.....	11
4.3.3	Feet / Meters.....	11
4.3.4	Magnetic Head / Cat whisker .....	12
4.3.5	Normal / Slow.....	12
4.3.6	Buzzer On/Off.....	12
4.3.7	Measurement Time.....	13
4.3.8	Bluetooth® Communications.....	13
4.3.9	Calibrate.....	14
4.3.10	Comms Test.....	15
4.3.11	Dwell Measurement.....	16
4.3.12	Spin Test .....	17
4.3.13	Battery Condition .....	18
4.3.14	Meter Selection .....	19
4.3.15	Software Version .....	20
4.4	Serial Communications Interface .....	21
4.4.1	Data Conversion Example .....	23
4.4.2	The User Serial Interface Program.....	25
4.4.3	Quick-Step Procedure for the User Serial Interface Program.....	29
4.4.4	Operating the Special Functions Using Serial Communications .....	31
4.5	Changing the Batteries.....	32
4.6	Maintenance and Repair Procedure.....	32
<b>5.</b>	<b>Specifications .....</b>	<b>33</b>
<b>Appendix A</b>	<b>Capturing a Spin Test.....</b>	<b>35</b>
<b>Appendix B</b>	<b>Measuring Meter Dwell .....</b>	<b>40</b>
<b>Appendix C</b>	<b>Serial Port Echo Command .....</b>	<b>41</b>
<b>Appendix D</b>	<b>Example Calibration Certificate.....</b>	<b>42</b>

# 1. Introduction

(The functions described in this manual apply to **PVD100** software Version 2.5)

The Hydrological Services Point Velocity Display (**PVD100**) is a small electronic device that can be used to measure flow velocity from most any mechanically rotating current meter. A superior feature of the **PVD100** is its ability to "clean" the signal and interface directly to a PDA, PocketPC, or other computing device and provide serial data that can be used by the external device to compute discharge. Meters using a cat whisker head and ball and wire contact to perform a mechanical switch closure can be used with the **PVD100** to produce a clean, noise-free signal. To measure and compute velocity, the **PVD100** provides a *User Serial Interface Program* (USIP). This USIP is used to enter the rating of the current meter and can support up to two meters with each meter having up to three rating equations with three rotations/sec ranges.

The **PVD100** operates with two AA batteries and can mount directly onto a top-setting wading rod. It offers connectivity between the current meter and a hand-held computer using either a connecting lead or an optional *Bluetooth*<sup>®</sup> wireless interface. Commands can be sent to the **PVD100** to perform a measurement and make operating selections. The **PVD100** can operate with current meter velocities from less than 0.015 m/sec to more than 6.1 m/sec for a Price AA meter. The **PVD100** also provides a slow-speed mode to improve measurements with extremely slow rotating current meters [velocities less than 0.076 m/sec]. The **PVD100** does not need to be connected to an external device to operate. The visual indicators, LCD and internal buzzer of the **PVD100** can be used to make a conventional current meter measurement and compute water velocity.

As you continue to read this manual, many features and operating capabilities of the **PVD100** will be revealed and described. The **PVD100** is extremely easy to use and yet versatile enough to offer selections to operate in a wide variety of scenarios and field settings. Its lightweight design allows the unit to connect directly onto the phone jack connection of a top-setting wading rod giving the user a nearly 'hands free' feel of operation. A single press of a button can begin a measurement. With its optional *Bluetooth*<sup>®</sup> capability, true 'wireless' connectivity can be made.

The software functions described in these instructions are sufficiently detailed for developers to integrate the **PVD100** with other hardware and software devices giving users the ability to develop their own applications.

As an added benefit, whenever the **PVD100** is inactive, the **PVD100** will automatically turn itself *Off* after 5 minutes to help conserve the batteries. When the **PVD100** turns *Off*, all important settings are saved in memory, eliminating the burden of re-setting up the device when the unit is turned back *On*. To turn it *On*, simply press the ON/OFF button and all previous settings are restored ready for the user to begin a measurement.



## 2. Product Overview

### 2.1 Overview

The **PVD100** can measure and display velocity. Velocity can be either displayed in meters/sec (m/sec) or feet/second (ft/sec) and is chosen by the user in a menu. When a measurement is being made, the **PVD100** counts contact closures, measures elapse time, and computes velocity to a precision of 0.001 m/sec or 0.01 ft/sec. The velocity is computed based on a selection of a meter rating again chosen from a menu. During a measurement, the **PVD100** sends through the serial port the number of accumulating meter contact closures and elapsed time at 1-second intervals. At the end of the measuring period, typically set for 40 seconds, a final count of the total number of contact closures and total measurement time is transmitted. From this data, a connected hand-held computer with an appropriate applications program can compute velocity for a discharge computation.

One of the most important operating features of the **PVD100** is the ability to signal process each contact closure. Contact closures from any type of meter are inherently noisy causing miscounting or double counting. The **PVD100** samples the input signal from the connected meter and examines the signal to determine if a contact closure has occurred and if successive signals are of the same characteristics. The **PVD100** then determines contact closure conditions and either counts the signal closure or eliminates the condition as a noise pulse and does not count the signal. For cat whisker contacts, this becomes extremely important since cat whisker contacts offer the poorest quality for marking and counting rotations.

The **PVD100** offers (2) modes of operation, i.e. NORMAL and SLOW speed mode. NORMAL is selected for meter rotations  $>0.076$  m/sec while SLOW mode is for velocities below 0.076 m/sec. To improve noise rejection, the sample rate of the input signal at the SLOW speed mode (lower velocities) is 1/10 of the sampling rate that occurs during NORMAL mode. This slower sampling rate improves performance for back rotations and corroded whisker contacts at extremely low meter cup rotations. It is important to know that the **PVD100** offers operational overlap at this 0.076 m/sec velocity selection in either mode and therefore it is not necessary for the operator to know precisely the velocity of water for selecting either mode.

Another important feature of the **PVD100** is the ability to detect faulty connections from the meter through the wading rod to the connected **PVD100**. During power up of the **PVD100**, a calibration of the input signal is performed. If a connection short is detected or other condition such as faulty input electronics, the **PVD100** signals the operator of the condition (by flashing the COUNT indicator) until the faulty condition is removed. Open circuit fault conditions are observed simply as a failure to detect a contact closure. A very important feature of the **PVD100** is the ability to detect a signal short during a measurement. If such a condition is detected, the '\*' symbol is displayed until the fault condition is removed. Importantly is the appearance of the '\*' symbol after the measurement to show the operator that a fault condition occurred during the measurement and that the measurement should be repeated. The measurement data that is transmitted through the serial port is also flagged to indicate a faulty measurement.

### 3. Installation

#### 3.1 Hardware Connections

##### Current Meter Input Connector

The **PVD100** provides two banana plug connections to the current meter.

The DB9 female connector on the **PVD100**, provides the RS232 interface and the signal driver output.



**RS232 Interface** – This interface is designed to directly connect to a handheld computer with an RS232C interface. Use the Comms Test function to test this interface.

Pin	PVD100 Signal Description	Direction
1	N.C.	
2	Tx Data (RS232 data output)	→
3	Rx Data (RS232 data input)	←
4	N.C.	
5	Data Ground 0V	↔
6	N.C.	
7	N.C.	
8	N.C.	
9	Signal Driver (O/C output)	→

**Signal Driver Interface**—Pin 9 provides an interface to other instruments that may use a current meter to perform velocity or flow measurements. Examples include the JBS Instruments’ AquaCalc and Sutron’s DMX Discharge Measurement Recorders. The signal provided through this connection simulates a current meter contact closure. Whenever a contact closure is detected from the current meter, the **PVD100** outputs through this connector, a fixed pulse-width driving signal that represents the contact closure. The signal driver is an open-drain Field Effect Transistor (FET) that will act like a switch. The signal is processed by the **PVD100**. To verify operation of this signal with other equipment, use the Comms Test function which simulates a contact closure and operates this output.

**CAUTION : Do not connect any type of DC voltage directly to pin 1 without a limiting resistor as this will permanently damage the driver circuit.**

## 4. Operation

### 4.1 Description of Controls

#### 4.1.1 Pushbuttons

The **PVD100** has three front panel buttons that are used to turn power *On* and *Off*, view menus, and choose operating settings. The buttons are labeled as follows :

**ON/OFF** – This button is the far left button on the front panel and is used to turn power *On* and *Off* on the **PVD100**. It is also used to quit from operating functions or exit from selections.

To turn *On* the **PVD100**, depress and release the ON/OFF button. The **PVD100** will turn *On* and go through a short initialization restoring settings and selections. The **PVD100** will then perform a self-calibration. Some settings and selections are stored permanently in memory even when the batteries are changed.

To turn *Off* the **PVD100**, press and hold the ON/OFF button for more than 3 seconds. The **PVD100** will turn off all indicators and the LCD, and then permanently store all user selectable settings. These settings will be automatically restored the next time the **PVD100** is powered on.

The **PVD100** will automatically shut off after (5) minutes of no activity (i.e. no meter contact closures, no serial port activity, no button presses and Bluetooth switched off or in Discover mode.)

**SELECT** – This center located button is used to perform selections within the different menus, and for special operating functions, this button is used to begin or start an operation.

**FUNCTION** – This button, located on the far right of the front panel, is used to go into a selection menu. If a measurement is not in progress, depressing this button will bring up a series of menus for choosing operating selections and functions.

When the **PVD100** is first turned on, previously selected settings are restored and the battery is checked. When the battery-check message appears on the LCD, the operator is required to acknowledge the message by depressing any button (i.e. ON/OFF, SELECT, or FUNCTION). After acknowledging the battery condition message, the **PVD100** performs a self-calibration. This calibration automatically adjusts the internal electronics for the conductivity of the water and check for any meter fault conditions. After this calibration, the **PVD100** shows the Main display.

**NOTE : When all 3 buttons on the PVD100 are held down simultaneously, the electronics performs a hardware reset, which is the same as removing and reinstalling the batteries!**

### 4.1.2 Indicator LEDs

The **PVD100** provides two LED indicators to show the unit is operating and to indicate current meter contact closures. Both indicators also show cable faults and other operating conditions of the **PVD100**. The following is a brief description for each indicator.

**COUNT** (*Orange* LED)—This indicator will flash whenever a contact closure from the meter has been detected. It also will indicate when special functions such as the “Meter Dwell Measurement” are being performed or the User Serial Interface program has been invoked. In the case of a detected fault, the indicator will turn *On* and stay *On* until the fault is cleared.

**OPERATING STATUS** (*Green/Red/Blue* LED)—This indicator remains illuminated whenever the **PVD100** is turned *On* and showing the operating status mode. The LED has three colors showing the type of meter (Magnetic Head or Cat Whisker Head) selected as well as Bluetooth® operational status. *Green* indicates the Magnetic Head is selected and *red* indicates the Cat Whisker Head is selected. *The operating default (power-up setting) is Magnetic Head.* The indicator also shows the operating mode. If the indicator is not blinking, then the operating mode is ‘Normal’. If the indicator is blinking rapidly, then the operating mode is ‘Slow’.

### 4.1.3 Factory Default Settings

The **PVD100** can be set with Factory Settings (or defaults) and these settings allow the **PVD100** to operate with preset conditions. These settings can be changed. To set the **PVD100** with Factory Settings, depress and hold the FUNCTION button, then turn *On* the **PVD100**. When the ‘Factory Settings’ message appears on the display, the FUNCTION button can be released.

The following is a list of the Factory Settings:

- Magnetic Head/Cat Whisker Head selection set to **MAG**, Magnetic Head meter
- STATUS is set to Normal speed
- Measurement Time is set to **40**-seconds
- The Buzzer is turned *Off*
- The following are the rating equation defaults:
  - o A: S/N 1000-00 (Meter ‘A’ Serial Number)
  - o 1 Rating (Number of ratings or equations)
  - o 1:  $2.2048(n)+0.0178$  (Rating equation, n= rotations/sec)
  - o B: S/N 2000-00 (Meter ‘B’ Serial Number)
  - o 1 Rating (Number of ratings or equations)
  - o 1:  $0.9604(n)+0.0312$  (Rating equation, n=rotations/sec)
- Meter ‘A’ selected for velocity computation
- Feet – Meters/second display set to ‘Feet’/sec
- All other settings are initialized to ‘0’ or turned *Off*

## 4.2 The Main Display

The following describes the Main display presentation on the LCD. Note: This display presentation is shown when the Menu selection VELOCITY/COUNTS is set to COUNTS.

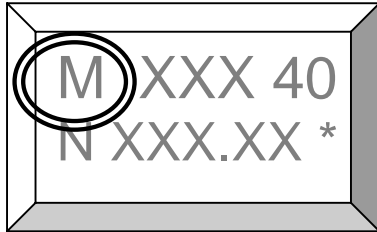

This display position shows the selection of the meter contact switch type. The selection can be M for a Magnetic Head contact or C for a Cat Whisker contact switch.

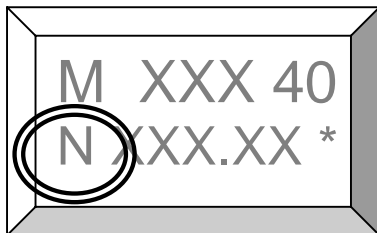

This display position shows the selection of the operating speed. The operating speed (or mode) selection can be N for Normal Speed (for velocities >0.076 m/sec) or S for Slow Speed (velocities <0.076 m/sec).

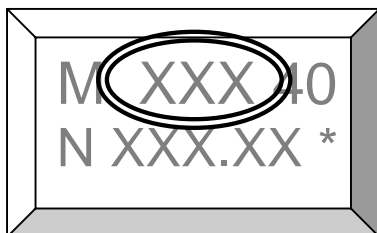

This display position shows the total accumulating meter contact counts during a measurement. Maximum number that can be shown is 999. Whenever meter contact counts exceed 999, the **PVD100** will continue to count but the most significant number position will begin to show special characters such as ‘.’ or ‘;’, etc. These characters indicate to the operator that a rollover count of ‘999’ has occurred.



This display position shows the total elapsed time of the measurement. During a measurement, the display shows elapsed time in seconds. When the measurement is completed, the display shows the total elapsed time to a tenth of second. If any measurement exceeds 300 seconds of elapsed time, the display will show the final elapsed time only in seconds when the measurement is completed. A ‘^’ character is shown in front of the accumulating elapsed time during and after completion of the measurement to indicate elapsed time has exceeded 300 seconds. The maximum displayed number is 999, however the **PVD100** will ‘roll-over’ to ‘0’ and continue to count until a meter contact closure is detected. To terminate the measurement upon the next meter contact closure, depress the ‘SELECT’ button. To terminate the measurement at any time and stop the count, depress and release the ‘ON/OFF’ button. After the measurement, to clear the total elapsed time, depress and release the ON/OFF button while in the Main display.

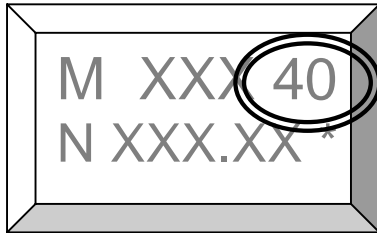

This display position shows the selection of the measuring interval. The measuring interval is chosen within a selection menu. The measuring interval is selected in 10-second increments to a maximum of 90 seconds. A measuring interval selection of '0' means a 'continuous' measurement with no time limit. With this time interval selection, the operator must depress the 'SELECT' button to stop the measurement at the next meter contact closure or the 'ON/OFF' button to simply stop and end the measurement.

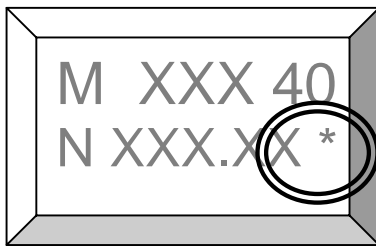

This display position shows the indication of a current meter fault. When the indicator appears, a meter fault has been detected. When the fault is cleared, the indicating character will disappear. If a fault has been detected during the measurement, the symbol will appear at the end of the measurement and will remain shown on the display until a new measurement is made.

**In Summary** (VELOCITY/COUNTS selected for COUNTS)

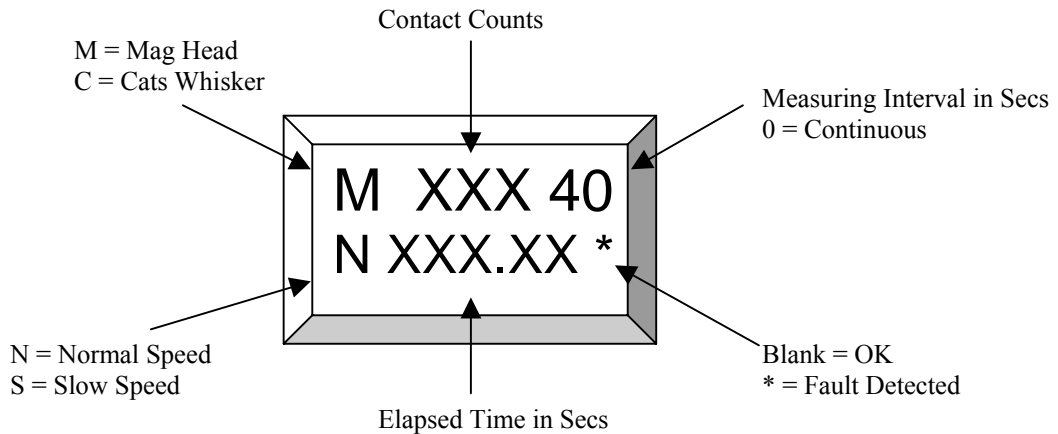

The following describes the Main display presentation on the LCD when the Menu selection VELOCITY/COUNTS is set to VELOCITY.

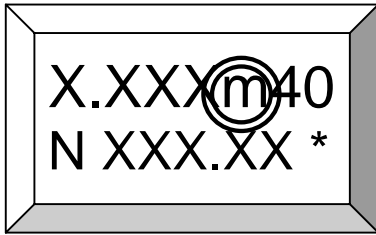

This display position shows the units as either 'm' for meters/second or 'f' for feet/second. The selection is performed in the FEET/METERS menu selection.

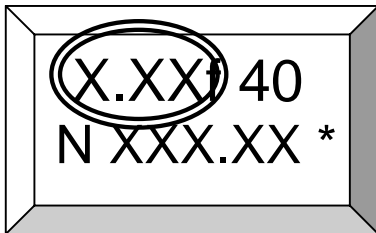

This display position shows velocity. Velocity precision (number of decimal places) is presented based on the selection of either feet/second or meters/second. If the FEET/METERS selection menu is set for FEET, the display will show velocity to two decimal places, while if the selection is set to METERS, the display will show velocity to three decimal places.

(**Trick:** if you want to get more resolution in the display of feet/second, simply select meters/second knowing that the rating equation is entered as feet/second. When ratings are entered, they are dimensionless; hence the calculation is performed without units. You must know that the rating is entered as feet/second even though the display shows meters/second.)

**In Summary (VELOCITY/COUNTS selected for VELOCITY)**

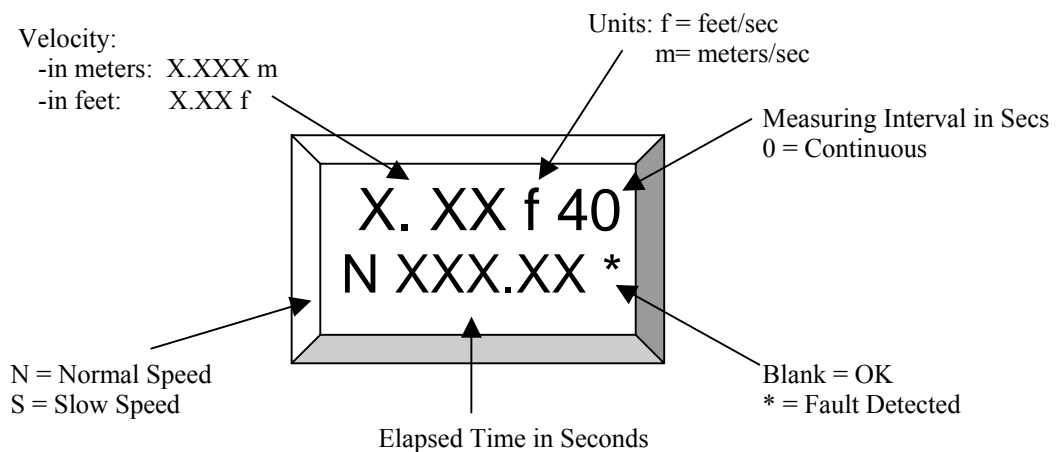

### 4.3 The Menus

To review or choose operating conditions and settings, a series of menus provide for each selection or function. To enter a menu, depress and release the FUNCTION button. Each time the FUNCTION button is depressed, a new menu is presented. To make a selection within a menu, depress the SELECT button. For most menus, an arrow character, '→', points to or shows the present selection within that menu. To exit from a menu at any time, depress and release the ON/OFF button. To continue through the menus, depress and release the FUNCTION button. Menus can only be viewed when a measurement is not being performed.

#### 4.3.1 Special Operating Functions

Within the **PVD100** are special operating functions that offer tools for adjusting the current meter and measuring its performance. These special functions are described in order of appearance within the menu list. Refer to **Section 4.4.4** below for the details of operating these functions using the serial communications interface.

#### 4.3.2 Velocity / Counts

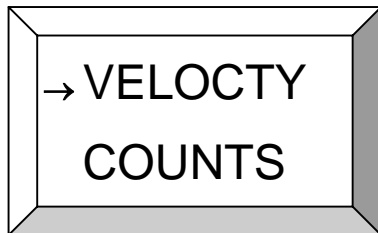

This is the first menu. The menu allows selection of the main display to show velocity; or counts and meter type selection. Use the FUNCTION button to select this menu, then press SELECT to toggle between Velocity (spelled VELOCITY in menu) or Counts. Press ON/OFF to return to the main display or press FUNCTION to step to the next menu item.

#### 4.3.3 Feet / Meters

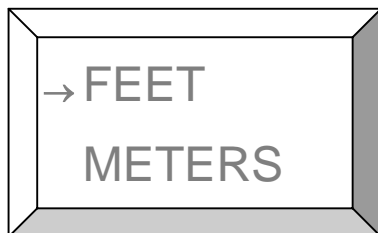

Use the FUNCTION button to select this menu, then press SELECT to toggle between Feet or Meters. Press ON/OFF to return to the main display or press FUNCTION to step to the next menu item.

#### 4.3.4 Magnetic Head / Cat whisker

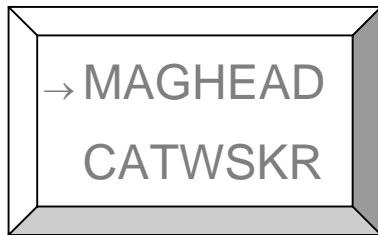

Allows selection between a Magnetic Head contact or a Cat Whisker contact switch. Use the FUNCTION button to select this menu, then press SELECT to toggle between Magnetic Head or Cat Whisker contact. Press ON/OFF to return to the main display or press FUNCTION to step to the next menu item.

One of the most important operating features of the **PVD100** is the ability to signal process each contact closure. Contact closures from any type of meter are inherently noisy causing miscounting or double counting. The **PVD100** samples the input signal from the connected meter and examines the signal to determine if a contact closure has occurred and if successive signals are of the same characteristics. The **PVD100** then determines contact closure conditions and either counts the signal closure or eliminates the condition as a noise pulse and does not count the signal. For cat whisker contacts, this becomes extremely important since cat whisker contacts offer the poorest quality for marking and counting rotations.

#### 4.3.5 Normal / Slow

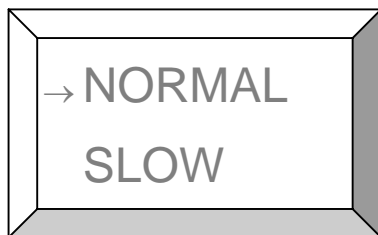

Use the FUNCTION button to select this menu, then press SELECT to toggle between Normal or Slow. Press ON/OFF to return to the main display or press FUNCTION to step to the next menu item.

The **PVD100** offers (2) modes of operation, i.e. NORMAL and SLOW speed mode. NORMAL is selected for meter rotations  $>0.076$  m/sec while SLOW mode is for velocities below 0.076 m/sec. To improve noise rejection, the sample rate of the input signal at the SLOW speed mode (lower velocities) is 1/10 of the sampling rate that occurs during NORMAL mode. This slower sampling rate improves performance for back rotations and corroded whisker contacts at extremely low meter cup rotations. It is important to know that the **PVD100** offers operational overlap at this 0.076 m/sec velocity selection in either mode and therefore it is not necessary for the operator to know precisely the velocity of water for selecting either mode. When in SLOW mode, the status LED flickers, and the sounder beeps longer whenever the whisker contacts are made.

#### 4.3.6 Buzzer On/Off

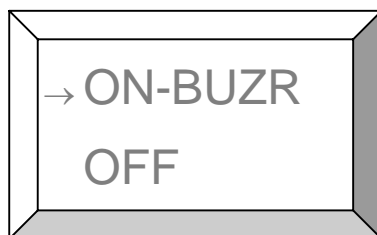

Use the FUNCTION button to select this menu, then press SELECT to toggle between Buzzer *On* or *Off*. Press ON/OFF to return to the main display or press FUNCTION to step to the next menu item.

### 4.3.7 Measurement Time

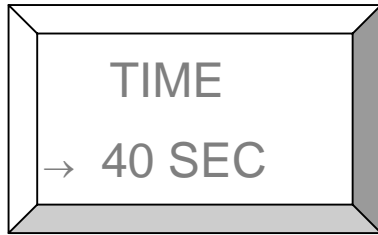

Use the FUNCTION button to select this menu, then press SELECT to increment the time in 10 second steps between 00 and 90 seconds. At this instant the selection is saved, so either press ON/OFF to return to the main display or press FUNCTION to step to the next menu item.

This is the nominal measurement time used when taking a current meter reading. When the time is set to 00 seconds, the timer runs until stopped manually by pressing the SELECT button, which completes the measurement at the next contact closure.

### 4.3.8 Bluetooth® Communications

**Bluetooth**® provides for a wireless link to an external device such as a PocketPC (PDA) or laptop that eliminates the serial RS-232 cable link connection. **Bluetooth**® is a wireless standard (IEEE 802.14) that offers a transparent serial port protocol for communication. Since the **PVD100** can output data and be controlled using the RS-232 serial interface, the physical cable connection can be eliminated using **Bluetooth**®. When the **PVD100** is turned *On*, the **PVD100** determines if **Bluetooth**® is installed. If available, **Bluetooth**® can be enabled and ‘discovered’ by another **Bluetooth**® device to establish a connection. Set the external device’s communication protocol in the following manner:

Baud Rate : 19200  
 Data bits : 8  
 Stop bits : 1  
 Parity : None  
 Flow control : None



Use the FUNCTION button to select this menu, then press SELECT to toggle between **Bluetooth**® *On* and *Off*, then press ON/OFF to enable **Bluetooth**®.

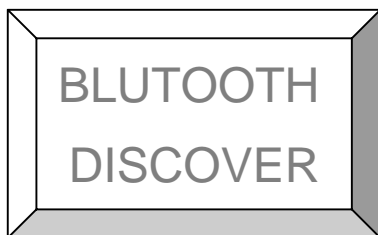

The following display presentation is shown when setting up and enabling **Bluetooth**®.

When this display is presented, the STATUS indicator will be *blue* and flashing at a rate of two quick flashes every two seconds. When another **Bluetooth**® compatible device is in proximity of the **PVD100**, and the devices application requests a connection, each automatically establishes the **Bluetooth**® serial interface protocol. When the connection has been established, the following display is shown on the **PVD100** display:

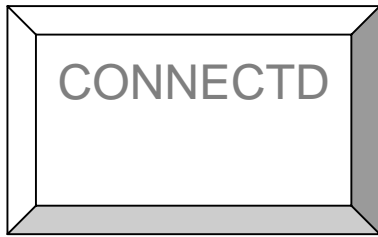

When a wireless connection is made, the STATUS indicator will show a solid *blue* color continuously – and the display will read “**CONNECTD**” for a few seconds before automatically jumping to the Main Display.

When making a connection with another *Bluetooth*<sup>®</sup> device for the first time, first examine and prepare the required enabling features of the external device for *Bluetooth*<sup>®</sup> connection. Enable the *PVD100 Bluetooth*<sup>®</sup> function and allow the external device to ‘discover’ the *PVD100*. When the external device makes ‘discovery’, the user must select the *PVD100* within the device’s menu setup and enable the connection. The external device should respond with a ‘connected’ message. The *PVD100* can now be used in a normal manner. All serial data sent from the *PVD100* will be transmitted via *Bluetooth*<sup>®</sup>. The connection can be disengaged by selection in the ‘-BT COM’ menu. The operator must monitor the integrity of the connection from the external device. If the connection becomes broken, the *PVD100* will revert back to *Bluetooth*<sup>®</sup> DISCOVER mode. This message will alert the operator of a disconnection between the *PVD100* and the external device. Connection will have to be rediscovered by the external device. Any active measurement occurring during a broken communications link will terminate and the measurement will need to be retaken. The *PVD100* will not automatically power down when *Bluetooth*<sup>®</sup> is enabled and connected. If *Bluetooth*<sup>®</sup> is *On* (or ‘connected’) when the *PVD100* is manually powered *Off*, the *PVD100* will go directly into ‘DISCOVER’ mode when the *PVD100* is turned back *On*. If the *PVD100* is in a ‘DISCOVER’ mode, the *PVD100* will remain in this mode for 5 minutes, then automatically turn *Off* if the *PVD100* does not become ‘connected’. However, when the *PVD100* is turned back *On*, the *PVD100* will automatically go into ‘DISCOVER’ mode.

#### 4.3.9 Calibrate

A calibration is performed automatically when the *PVD100* is turned on and when a measurement is actioned through the comms interface. Performing a calibration within the menu can be used to check the input electronics of the *PVD100* for proper operation when not connected to a meter. It is also useful to check the connectivity to the current meter. If a detectable fault is found, the COUNT indicator will turn *On* and stay *On* and the STATUS indicator will turn *On* and *Off* to indicate a connection short or some other electronics fault. When the fault is cleared, the indicators will reflect their fault-free operating condition. Finally, it may be necessary to recalibrate the *PVD100* in areas where the water has a high conductivity. Use this function when the meter and wading rod or meter mounting are completely in the water. This will insure a proper calibration and adjustment of the *PVD100* to the water conductivity prior to making a measurement.

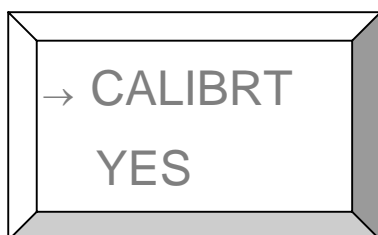

To perform a manual calibration, use the FUNCTION button to select this menu, then press SELECT to toggle to YES and perform the calibration. (This takes less than 1 second)

### 4.3.10 Comms Test

The ‘Serial Port Test’ function, called ‘COMTEST’ in the menu, provides a way to test the setup of the serial communications interface between the *PVD100* and an external device connected (cabled or wireless) to the *PVD100*.

Set the external device’s communication port as follows :

Baud Rate : 19200  
 Data bits : 8  
 Stop bits : 1  
 Parity : None  
 Flow control : None



Use the FUNCTION button to select the COMTEST menu, then press SELECT to toggle the arrow to YES, then press ON/OFF to start the test.

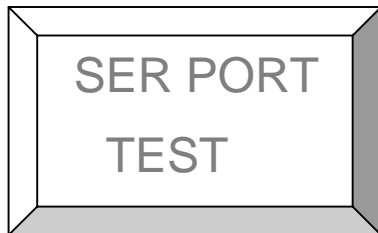

When the test is invoked, the display will read “SER PORT TEST” and the single ASCII character ‘1’ is transmitted through the serial interface. If the connected device’s serial communications interface is properly configured, the character will be received. The character is sent at a rate of about two times a second. Depressing and holding the ‘SELECT’ button for more than two seconds can send an alternate ASCII character string. This alternate character string represents the data string format that would normally be sent through the

serial interface when making a current meter measurement. To deselect this alternate character string, depress and hold the ‘SELECT’ button again until the single character ‘1’

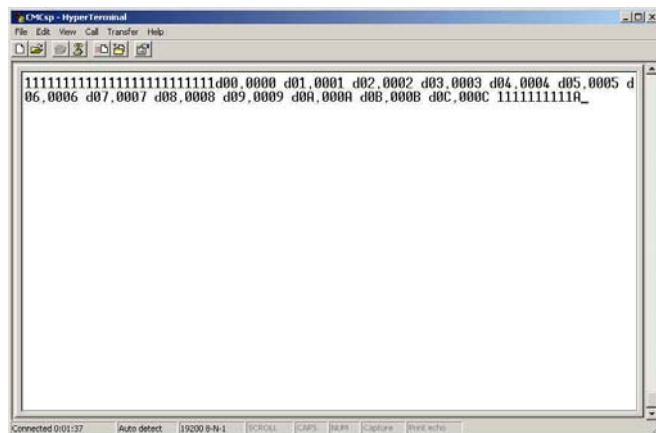

appears. The screen capture in the figure to the left, shows both character strings sent through the serial interface while this test is being performed. The string sent through the serial interface can be viewed when using the *Microsoft* program *HyperTerminal*. When the test is invoked, the ‘COUNT’ indicator flashes and the Signal Driver O/C output operates (to simulate a contact closure) and the ‘STATUS’ indicator shows an alternating *Red/Green* flash.

To end the test, simply depress and hold the ‘ON/OFF’ switch until the ‘STATUS’ indicator stops flashing, then release the ‘ON/OFF’ switch. *HyperTerminal* is an ‘Accessories’ program in the *Microsoft*® operating system found on most laptops and computers. Operating selections, measurement data, and special *PVD100* operating functions can all be selected and controlled through the serial interface using *HyperTerminal* or any other comms terminal application.

### 4.3.11 Dwell Measurement

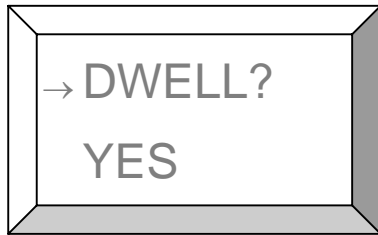

Using the Function button scroll to the “Dwell ?” menu and press Select to move the arrow to Yes, and then press the ON/OFF button to enter the dwell function. Refer to **Appendix B Measuring Meter Dwell** for a further explanation of this function.

The opening display for the special operating function called ‘DWEELL’ is shown. This function measures the dwell angle (ratio of meter contact time to the total time for a single rotation) for a meter contact and is useful for making adjustments to a cat whisker type meter in the field. For a cat whisker contact head, the optimum adjustment is 60° or a single meter cup width (US Geological Survey Price AA or Pygmy meter). A variation to an adjustment of +/- 10% is acceptable. For this function, (3) measurements are taken from a rotating meter. The results of the measurement are displayed in whole degrees of dwell. The measure of dwell angle for the magnetic head contact does not apply but can be performed. To perform the measurement, the following steps are used :

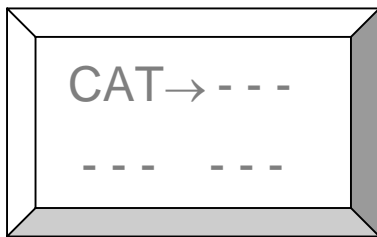

For a cat whisker contact head, the optimum adjustment is 60° or a single meter cup width (US Geological Survey Price AA or Pygmy meter). A variation to an adjustment of +/- 10% is acceptable. For this function, (3) measurements are taken from a rotating meter. The results of the measurement are displayed in whole degrees of dwell. The measure of dwell angle for the magnetic head contact does not apply but can be performed. To perform the measurement, the following steps are used :

The measure of dwell angle for the magnetic head contact does not apply but can be performed. To perform the measurement, the following steps are used :

1. Before enabling this function from the menu, select the type of contact head, i.e magnetic head or cat whisker head contact. This is done from a different menu.
2. After selecting the type of meter contact head, when the ‘DWEELL’ measurement function is enabled, the opening display presentation will show the type of meter contact selected to make the measurement. **CAT** is shown when a cat whisker head is chosen and **MAG** is shown when a magnetic head contact is chosen.
3. From the ‘DWEELL’ measurement function display as shown above, free spin the meter at a rate of about 2 rotations per second.
4. Depress the ‘SELECT’ key.
5. As each measurement is taken, a whole number display of dwell angle (in degrees) will be shown. If no contact closures are detected within a 4 second period, the display will read “NO DWEELL”. Conversely, if the contact closures are too long, the display will read “EX DWEELL” indicating exceeded dwell.
6. To repeat the measurement, simply spin the meter and depress the ‘SELECT’ key.
7. During the measuring of dwell angle, the ‘STATUS’ indicator will flash ‘red’ at each detected contact closure to show a cat whisker head is selected and the display shows **CAT**. If the STATUS indicator is flashing *green* during the measurement, the meter selection is Magnetic Head and the display will show **MAG**. Again, select the type of meter contact head before selecting this function to measure the dwell angle of the meter.
8. To exit from this function, simply depress the ‘ON/OFF’ button.

### 4.3.12 Spin Test

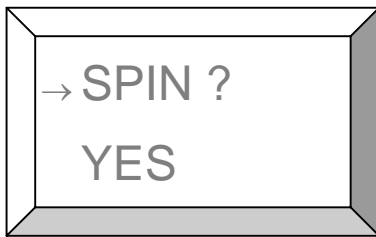

Using the Function button scroll to the “Spin ?” menu and press SELECT to move the arrow to Yes, and then press the ON/OFF button to enter the spin function.

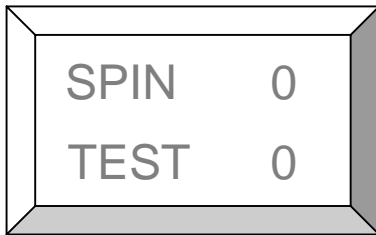

This opening display for the special function called ‘SPIN TEST’ is shown. A ‘spin test’ is an elapsed time measurement from the time a meter is spun to when rotation of the meter stops. The operator controls the start and stop time for a total elapsed time measurement. The test measures total elapsed time and total number of meter counts detected. Start and stop time is controlled by depressing the ‘Select’ button. Perform the following steps to ‘spin test’ a meter:

1. Before selecting the ‘SPIN TEST’ function, select the type of meter contact, i.e. cat whisker head contact or magnetic head contact.
2. From the opening display presentation as shown above, depress the ‘SELECT’ button.
3. Spin the meter. When the **PVD100** detects the first contact closure (which is not counted) the elapsed time counts begins. Each following contact closure detected is counted and shown on the top line of the display. The bottom line of the display

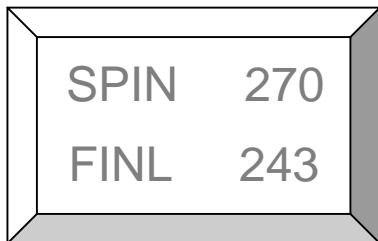

shows the continuing elapsed time in seconds. When the meter stops rotating, depress the ‘SELECT’ button again. The display presentation shown in the figure on the left gives the final summary of the total number of contact closures detected and total elapsed time in seconds. Maximum number of elapsed time is 999 seconds and the maximum total number of meter counts that is displayed is 999.

4. To exit from the ‘SPIN TEST’ function at any time, depress the ON/OFF button. The **PVD100** will exit from the function; perform a calibration, and then return to the Main display.

**\*\*\*NOTE\*\*\*** : While the Spin Test is in progress, serial data is automatically transmitted on the serial port. See **Appendix A** for an explanation of how to collect and display the results of a Spin Test. The Spin Test can also be invoked using the serial interface command ‘N’. Refer to **Section 4.4.4 Operating the Special Functions Using Serial Communications** and **Appendix A** for a detailed description of how to perform a Spin Test using the serial communications port.

### 4.3.13 Battery Condition

For battery conditions, the **PVD100** continuously monitors the power level of the batteries. In the event a low battery condition is detected, the **PVD100** turns *On* both the *red* and *green* LED on the STATUS indicator to inform the operator. The menu function showing the battery condition is also messaged to show a low battery condition. If the **PVD100** is turned *Off* with a low battery condition, upon turning *On* the **PVD100**, only the *red* LED on the STATUS indicator is turned *On* (at a lower indication level) to inform the operator that the **PVD100** will not turn *On* until the batteries are changed. This prevents poor operation from a low battery condition. Whenever the **PVD100** is turned *On*, the battery is checked and the condition of the battery is displayed for the operator. The operator must acknowledge the message before any other operation of the **PVD100** can be performed. A low battery condition is set at approximately 2.8 V dc (or 1.4Vdc/battery). The **PVD100** will work at lower battery voltages but is not recommended since batteries tend to deplete very quickly at lower voltages.

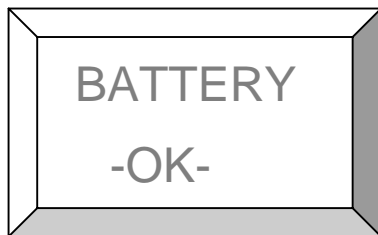

Use the FUNCTION button to select this menu and view the battery condition.

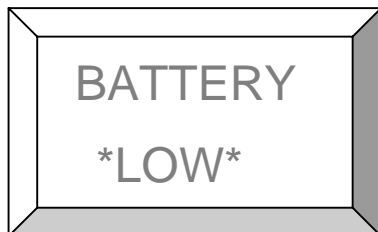

If the battery voltage falls below 2.8V then it will be indicated as low.

#### 4.3.14 Meter Selection

The meter selection menu is used to select the meter that will be used in the measurement and for the final computation of velocity. There are two meters that may be selected and they are designated by the **PVD100** as 'A' and 'B'. The ratings for the two meters must have already been entered using the special serial communications program designated 'User Serial Interface Program' (refer to Section 4.4.2 for a description of this interface program). Each meter has a serial number and a rating for the meter, which can have up to (3) equations and (3) ranges of rotations/second (designated as 'n'). It should be noted that during a measurement, only the first term (slope) of any rating selected within the menus is used in the calculation of velocity. This is to give the operator a close approximation of velocity while the measurement is being performed and is intended only for real time display purposes. At the end of the measurement, the full calculation is performed. If a meter has more than (1) rating, then the proper range (n) value (rotations/second) is computed to select the proper rating and perform the final velocity calculation. There is no LCD menu for displaying the range values in the format they are entered via the serial interface.

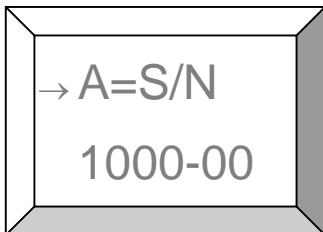

Use the Select button to view each meter's serial number and rating(s). To select a meter for the final velocity calculation, use the Select button to bring the serial number into view, then press ON/OFF to return to the main display or press FUNCTION to step to the next menu item. To select a specific rating to use for calculating velocity only while the measurement is taking place, use the select button to view the specific rating, and then press

ON/OFF to return to the main display or press FUNCTION to step to the next menu item. When the serial number is viewed, the **PVD100** automatically selects the first rating equation (whether a meter has one or more ratings) for the real time display of velocity during a measurement. After a measurement and the final calculation of velocity, the user can select a different rating in the menu to see a different velocity calculation on the same measurement.

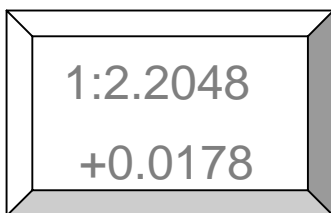

This display shows the first rating for the meter. The number of the rating is shown as the first digit on the top row of the display followed by a colon (:). Only numeric values are shown to verify the selection for the first and second terms for the meter. Press ON/OFF to return to the main display or press FUNCTION to step to the next menu item. Pressing the Select button moves the display to the next rating of the meter or to the serial number of the next meter.

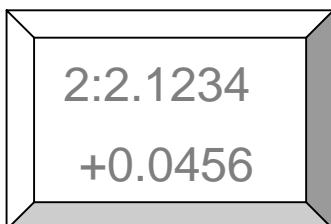

This display shows the second rating for the meter. Only the numeric values are shown to verify the selection for the first and second terms. Press ON/OFF to return to the main display or press FUNCTION to step to the next menu item. Press the Select button to go to the next rating or to the serial number of the next meter.

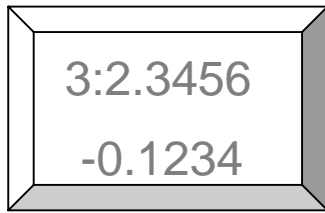

This display shows the third rating for the meter. Press ON/OFF to return to the main display or press FUNCTION to step to the next menu item. If the ON/OFF or FUNCTION button is pressed, this rating will be used to compute velocity only during a measurement using only the first term of the rating. For the real time display of velocity during a measurement, only the first term of the rating is used (i.e. 2.3456).

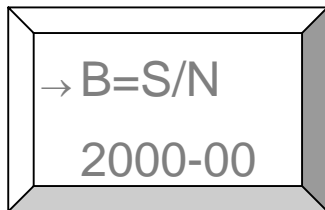

This display shows the serial number for meter 'B'. Press ON/OFF to return to the main display or press FUNCTION to step to the next menu item. In this display setting, the computation of velocity for the real time display will use the first rating of the meter even if the meter has more than one rating. Press the Select button to show the values of the first rating of the meter.

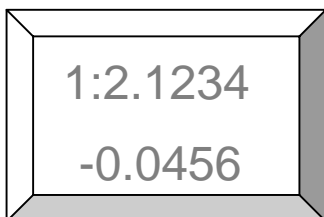

This display shows the first rating for the meter. Only the numeric values are shown to verify the selection for the first and second term for the meter. Press ON/OFF to return to the main display or press FUNCTION to step to the next menu item. If the Select button is pressed, the display will show the next rating or show the serial number of the next meter.

#### 4.3.15 Software Version

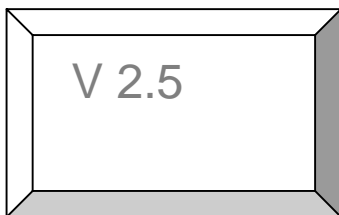

Use the FUNCTION button to select this menu and view the **PVD100** Software Version.

#### 4.4 Serial Communications Interface

The **PVD100** can be connected to a hand-held or notebook computer or any device that can transmit and receive serial communications using RS-232C or **Bluetooth**<sup>®</sup> using an application such as HyperTerm. Commands can be sent to the **PVD100** to perform special functions or select operating modes. The following describes the serial data requirements, commands, and data formats that are used for the serial communications interface :

**Baud Rate :**            **19,200 RS-232C**  
**Format :**               **8 data bits, no parity, 1 stop bit**  
**Flow Control :**       **None**

The following list shows the commands and functions that can be performed through the serial communications interface.

<u>Command</u>	<u>Function Performed</u>
<b>S</b>	Start a measurement
<b>T</b>	Terminate the measurement
<b>I</b>	Abort the measurement
<b>R</b>	Resend the last data string
<b>U</b>	Buzzer ON
<b>Z</b>	Buzzer OFF
<b>H</b>	Speed Select, set to Normal
<b>L</b>	Speed Select, set to Slow
<b>M</b>	Select Magnetic Head meter processing
<b>C</b>	Select Cat Whisker Head meter processing
<b>E</b>	Enter User Serial Interface Program (Meter ratings)
<b>P</b>	Start a measurement without performing a calibration
<b>Q</b>	Start a measurement with no time limit (continuous measure)
<b>V</b>	Software Version

**NOTE:** *Commands sent to the **PVD100** are case sensitive – and must be upper case only.*

When the commands ‘**S**’, ‘**T**’, and ‘**I**’ are received by the **PVD100** from an externally connected device, the **PVD100** sends an acknowledge character ‘**A**’ back to the device. For the ‘**S**’ command, the **PVD100** sends acknowledge character ‘**A**’ after the **PVD100** performs and completes the calibration. Note that invalid or unrecognized commands will result in a ‘?’ being transmitted through the serial port.

- S** – *Start a measurement*: Begins a measurement at the first contact closure detected. Number of contact closures and elapsed time counts are accumulated. At the first contact closure, the **PVD100** begins sending the accumulated contact closures and elapsed time counts through the serial port every second. The first data string transmitted through the serial port begins the start of the measurement interval with the meter contact closure count tally and elapsed time tally of ‘0’. Note that when this command is received by the **PVD100**, it automatically performs a calibration then monitors the input for meter contact closures. Following is the output data format sent to the externally connected device at the 1-second output rate:

**dnn,xxxx\_**

- d = preamble for indicating display data
- nn = number of meter contact closures, transmitted in HEX ASCII (hexadecimal notation)(i.e. 0-9,A-F)
- ,
- xxxx = counts of elapsed time measured as 0.003333 seconds/count, transmitted in HEX ASCII (i.e. 0-9,A-F) while in Normal mode and 0.03333 seconds/count while in Slow mode.
- \_ = space

This data format that is transmitted to the externally connected device can be used to display elapsed time and velocity while the measurement is being performed.

At the end of the measurement interval or if the ‘**T**’ command is received, the **PVD100** sends the last tally of accumulated counts and time in the following format:

**fnn,xxxx** or **enn,xxxx**

- f = final data, no detected faults
- e = final data, error detected during measurement; restart the measurement

The measuring interval is based on the user selected measurement time. When the measuring interval has been reached, (or the T command is received) the **PVD100**, upon the next meter contact closure, will send the final data for that measurement. If there is no contact closure detected when the measurement interval has been reached, the **PVD100** will continue to send data and the user must send the ‘I’ command to abort the function. Note that the meter contact number, nn, is limited to a total of 255 counts (hexadecimal notation ‘FF’). If more than 255 counts are detected throughout the measurement interval, the count will rollover to ‘00’ and continue to accumulate counts. No fault condition is set if this occurs. This allows for continuous counting in excess of 255 counts occurring during the measuring interval. External processing software can easily detect this condition and process total meter counts when the measuring interval is completed. The same condition occurs for the elapsed time tally. This permits an elapsed time count of 218 seconds for a measuring interval before the count rolls over to ‘0000’.

- T** – *Terminate the measurement:* **PVD100** stops the measurement at the next contact closure and, at the next contact closure (which is counted), sends the last tally of accumulated counts and elapsed time as previously described.
  
- I** – *Abort the measurement:* The **PVD100** aborts the measurement. No final measurement data is transmitted.
  
- P** – *Start a measurement without doing a calibration:* This command is used to begin a measurement without performing a calibration. The command should only be used for a high velocity measurement that does not allow a calibration to be performed due to the rapid rotation of the meter cups.
  
- Q** – *Continuous measurement:* This command is used to continuously output a 1-second data display without a time limit. The **'T'** or **'I'** command must be used to terminate the operation.
  
- V** – The software version of the **PVD100** is sent in the following manner:

**vX.X**            Example: **v1.0**

#### **4.4.1 Data Conversion Example**

The data format of the **PVD100** is transmitted in HEX ASCII (base 16 numbers using the ASCII code which is displayable on any terminal) to provide efficiency in the number of data characters sent through the serial interface. Following is an example of the interpretation of the data. The example is given with the **PVD100** in NORMAL Speed mode.

Example:                    **d0C,0AF6**

Accumulated meter counts = **0C**<sub>16</sub> = **12**<sub>10</sub>

Elapsed time = **0AF6**<sub>16</sub> = **2806**<sub>10</sub> = (2806 counts x 0.003333 sec/count) = 9.35 secs

The data format says a total of 12 meter counts have been accumulated in 9.35 seconds.

Shown below is a simple *Excel* program that easily converts hexadecimal numbers to decimal (base 10) numbers. The column 'Decimal Conversion' shows the *Excel* formula.

	A	B
0	<b>Hexadecimal</b>	<b>Decimal</b>
1	<b>Number</b>	<b>Conversion</b>
2		
3	1F	=hex2dec(A3)

Data Format Notes

The data format presented by the **PVD100** during a measurement provides for displaying a computed velocity by an external device at a 1-second rate. The accumulating contact closure counts and time interval counts can be used in a rating equation to display velocity. At the end of the measuring interval, a final total of contact closures and interval time is then used to compute the measured velocity. For the Normal mode, the 1-second output data format displays the accumulating time interval counts based on a 300 Hz sample rate. The following example below shows how it would be presented using the 'HyperTerminal' program: NORMAL mode, 300 Hz sample rate, counts accumulating at a 1 Hz rate.

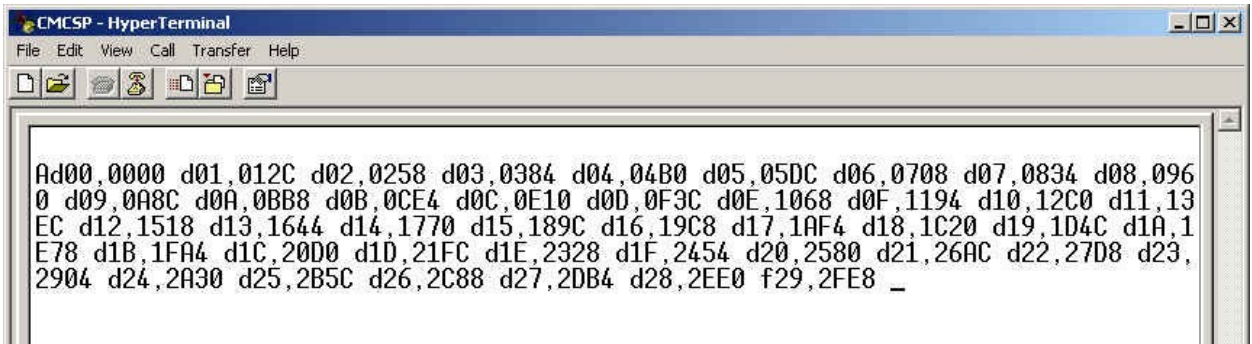

For Slow Speed mode operation, the display of the accumulating time interval counts differs in that the value is based on a 30 Hz sample rate. The following example below shows how it would be presented in the Slow Speed mode:

30 Hz sample rate, counts accumulating at a 0.25 Hz rate (1 count every 4 seconds)

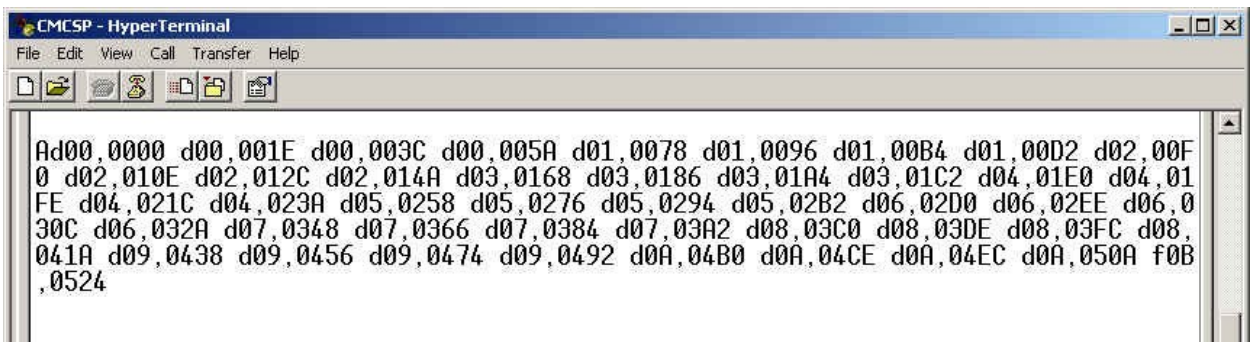

#### 4.4.2 The User Serial Interface Program

The **User Serial Interface Program** allows the user to input the rating(s) for a current meter. The user connects the **PVD100** to a laptop, desktop, PocketPC, or other type of field computing device having a terminal emulator software program (such as HyperTerm) for communication. Once connected, the user then enters on the remote terminal device the upper case letter '**E**'. Once entered, the user selects between meter '**A**' or '**B**' and then enters the following information about the current meter:

- a) Serial Number,
- b) Number of equations (or ratings),
- c) First term (slope) and signed second term (intercept) for the rating,
- d) A rotations/second range  $n$  (if a current meter has more than one equation for its rating).

The following procedure can be used to enter all information necessary for the **PVD100** to compute velocity for a measurement. To exit anytime from the **User Serial Interface Program**, use the '**Esc**' key.

**Step 1:** Connect the **PVD100** using the serial communications cable or *Bluetooth*® connection. If a *Bluetooth*® connection is desired, first enable the *Bluetooth*® connection between the **PVD100** and the remote terminal device before entering the **User Serial Interface Program**.

**Step 2:** To enter the **User Serial Interface Program** (USIP), enter '**E**' on the keyboard. The USIP responds with the following message:

```
A=S/N 1000-00
B=S/N 2000-00

A, B or S? _
```

The Serial Number for each meter is displayed followed by a selection request from the user. Selecting '**A**' means choosing meter '**A**' or meter #1. '**B**' designates meter #2. '**S**' is an entry that will provide a summary of the rating(s) and ranges for each meter and gives the user a way to verify entries.

**Step 3:** The user must enter '**A**', '**B**', or '**S**'.

*The following instructions will assume Meter 'A' has been selected.*

The USIP responds with the Serial Number for Meter '**A**' (or meter #1). For this example, the USIP responds with the following default Serial Number:

```
A: S/N 10000-00
```

The letter '**A**' designated above specifies the meter number and is not alterable by

the user. This is what the **PVD100** uses to distinguish between the two meters. The user enters any characters and numbers for the Serial Number. Up to seven alphanumeric, numeric, and special characters all can be used to give a serial number for the meter. Three control keys are used for position and data entry control:

- The '**Space bar**' key inserts a 'space' into the character position.
- The '**Backspace**' key moves the cursor position backwards without changing the character.
- The '**Enter**' or '**Carriage Return**', <CR> key accepts the entry and moves to the next data entry element.

**Step 4:** Enter the Serial Number for the meter. When the user has completed the entry, press the <CR> key to enter the Serial Number. The USIP responds with the following message:

**NUMBER OF EQUATIONS? 3**

Each meter ('A' or 'B') can have up to three equations for the full rating of the meter. The number 3 shown above indicates what was previously selected for the number of equations for the meter rating. The user enters '1', '2', or '3' for the number of equations for the rating. If the meter has been calibrated, the calibration certificate will show the number of equations that describe the full rating for the meter. Refer to **Appendix D** for an example of a calibration certificate supplied with a meter.

**Step 5:** The user enters '1', '2', or '3' for the number of equations for the rating. For this example, the number '3' is entered. The USIP responds with the following Range 1 value, **n**, in meters/second or feet/second;

**1: n < 0.50**

This is a default range and allows the user to enter the proper range as shown on the fan calibration certificate provided by Hydrological Services Pty Ltd. when the calibration of the meter was performed. There is no need to enter feet/second or meters/second since units are selected in a selection menu.

**Step 6:** Enter the Range 1 value as shown on the calibration certificate, then press <CR> on the keyboard (i.e.'Enter' key). Any numbers up to 9.99 can be used for the range. The **PVD100** will only allow the user to enter numbers. Three control keys are used for position and data entry control:

- The '**Space bar**' key moves the cursor position forward without changing the number.
- The '**Backspace**' key moves the cursor position backwards without changing the number.
- The '**Enter**' or '**Carriage Return**', <CR> key accepts the entry and moves to the next data entry element.

Once entered, the USIP responds with the following Range 2 value:

$$2: 0.50 < n < 3.75$$

This is a default range and allows the user to enter the proper range shown on the provided fan calibration certificate. Range 2 for a three equation fan rating is listed as the second range given for the second equation listed. Refer to **Appendix D** for an example. Again, any numbers up to 9.99 can be used for the range and only numbers can be entered. After entering the Range 2 value, press the <CR> key on the keyboard. The USIP responds with the final Range 3 value which the user is not required to enter:

$$3: n > 3.75$$

**Step 7:** After entry of the Range values, the user presses the <CR> key and the USIP responds with the first rating equation for the meter:

$$1: 2.2048[n]+0.0178$$

The first number shown on the line is the rating equation number. Up to three equations can be shown depending on the user's response to the 'Number of Equations...' entry. For data entry position and control, the following keys can be used:

- The 'Space bar' key moves the cursor position forward without changing the number.
- The 'Backspace' key moves the cursor position backwards without changing the number.
- The 'Enter' or 'Carriage Return', <CR> key accepts the entry and moves to the next data entry element.

When a number is entered, the cursor automatically positions to the next number entry position. For the sign, the USIP will only recognize the '+' or '-' keys. When the entry is completed, press the <CR> key to go to the next rating equation. For any rating equation, the maximum allowable number for the first term (slope) is 6.5535. The maximum allowable number for the second term (intercept) is 0.9999. At the completion of the entry, pressing the <CR> accepts the complete entry and displays the next equation (if there is more than one), otherwise the USIP moves to the beginning (*Step 2* above) to choose meter 'B' or review and make entry changes to meter 'A' or to request a Summary.

**Note:** Incorrect or unreasonable entries can give unexpected results for velocity calculations. Be sure to provide the proper entries for these ratings.

**Step 8:** After all entries have been completed, the user presses <CR> to display the Serial Numbers of both meters and make a selection. The USIP responds with the following message (as is shown in *Step 2* above):

**A=S/N 1000-00**  
**B=S/N 2000-00**

**A, B or S? \_**

For this display (as in *Step 2* above) 'S' is an entry that will provide a summary of the rating(s) and ranges for each meter.

Entering 'S' will show the following results (numbers shown are arbitrary and are for example):

```
-----  
A=S/N 1000-00  
  3 Ratings  
  
Range 1: n<1.23  
  2.3456[n]+0.2345  
  
Range 2: 1.23<n<4.56  
  1.2345[n]-0.1234  
  
Range 3: n>4.56  
  2.3456[n]-0.2345  
-----  
B=S/N 2000-00  
  1 Rating  
  
  0.1234[n]+0.0123  
-----
```

The summary listing shows meter 'A' having three equations to describe the rating while meter 'B' shows only one equation for the rating. When the summary has been displayed, the user enters any key entry including the 'space bar' key, <CR>, or 'ESC'. Entering <CR> or 'ESC' causes the program to end. Entering any character or the 'space bar' will move to display the Serial Numbers of both meters and make a selection as shown in *Step 2* above.

### 4.4.3 Quick-Step Procedure for the User Serial Interface Program

(Numbers are shown for example)

**Step 1:** Press 'E' on the keyboard.

USIP response: **A=S/N 1000-00**  
**B=S/N 2000-00**

**A, B or S? \_**

**Step 2:** Enter **A**, **B**, or **S**. (see *Step 7* for entry of 'S')

USIP response: **A=S/N 1000-00** *if the user enters 'A'*

*or*

**B=S/N 2000-00** *if the user enters 'B'*

**Step 3:** Edit the Serial Number, then enter <CR> ('Carriage Return').

USIP response: **NUMBER OF EQUATIONS? 3**

**Step 4:** Enter 1, 2, or 3.

USIP response: **1: 2.2048[n]+0.0178** *if the user enters 1 for Number of Equations*

*or*

**1: n < 0.50** *if the user enters 2 or 3 for Number of Equations*

Enter the first range value for *n* (rotations/second).

USIP response: **2: n > 0.50** *if the user enters 2 for Number of Equations*

*then*

**1: 2.2048[n]+0.0178**

*or*

**2: 0.50 < n < 3.75** *if the user enters 3 for Number of Equations*

Enter the second range value for  $n$  (rotations/second).

USIP response: **3:  $n > 3.75$**  *if the user enters 3 for Number of Equations*

*then*

USIP response: **1:  $2.2048[n]+0.0178$**

**Step 5:** Edit the equation, then press <CR>.

USIP response: **2:  $2.2048[n]+0.0178$**  *if the user enters 2 or 3 for Number of Equations*

*or*

**3:  $0.9604[n]+0.0312$**  *if the user enters 3 for Number of Equations*

**Step 6:** Edit the final equation, then press <CR>.

USIP response: **A=S/N 1000-00  
B=S/N 2000-00**

**A, B or S? \_**

**Step 7:** Enter 'S'. (Values are arbitrary and for example)

USIP response: -----

**A=S/N 1000-00  
3 Ratings**

**Range 1:  $n < 1.23$   
 $2.3456[n]+0.2345$**

**Range 2:  $1.23 < n < 4.56$   
 $1.2345[n]-0.1234$**

**Range 3:  $n > 4.56$   
 $2.3456[n]-0.2345$**

-----  
**B=S/N 2000-00  
1 Rating**

**$0.1234[n]+0.0123$**   
-----

**Step 8:** Press <CR> or 'Esc' key to exit the program or any key entry or 'space bar' key to repeat *Step 1*.

USIP response: A (acknowledge) and program ends.

*or*

A=S/N 1000-00

B=S/N 2000-00

A, B or S? \_

#### 4.4.4 Operating the Special Functions Using Serial Communications

The special function 'SPIN Test' can be operated using the serial communications interface. A laptop, desktop PC, or PocketPC using a terminal emulating package or *Microsoft®'s HyperTerminal* can be used to invoke the function. No menu selections in the **PVD100** are needed. The selection of the meter type and turning the buzzer *On* and *Off* can all be done using the serial communications interface. These functions can also operate using *Bluetooth®*.

The following list shows the commands and functions that can be performed through the serial communications interface.

<u>Command</u>	<u>Function Performed</u>
N	Spin Test
S	Start Spin Measurement (subcommand in 'Spin Test')
A	Stop Spin Measurement (subcommand in 'Spin Test')
U	Buzzer ON
Z	Buzzer OFF
M	Magnetic Head Meter
C	Cat Whisker Head Meter
I	Abort function

When the 'N' command is received by the **PVD100** from an externally connected device, the **PVD100** echoes acknowledge character 'N' back to the device.

Refer to **Appendix A** for details in using the Spin Test and capturing a 'spin test file'.

## 4.5 Changing the Batteries

**NOTE :** For optimum performance, the batteries should always be replaced with two good quality AA alkaline batteries !!

Simply clip open the two side panels as shown and remove the 4 screws, then flip the top cover forward.

Remove the old batteries and discard thoughtfully.

Insert the new batteries taking care of the battery orientation – which is stamped on the bottom of the battery enclosure.

After replacing with new batteries, if the Power ON/OFF button is depressed and the unit appears not to turn *On*, do the following:

- Depress and release all three buttons at the same time. This is the same as performing a hardware *Reset*. All settings will be restored and the unit will operate normally. Be sure not to hold down the FUNCTION button too long as this causes the PVD100 to power up with Factory Defaults. If this occurs, simply remove the batteries while the unit is *On*, then replace the batteries. All previous settings should be restored.

**Please Note:** Installing the batteries backwards will not damage the **PVD100**.

## 4.6 Maintenance and Repair Procedure

There is no specific maintenance for the **PVD100**. As with any electronic device, care must be taken to insure minimal exposure to moisture, dirt, or other contaminants. The unit has waterproof connectors and an “O” ring seal between the two case halves, which prevents the ingress of water and is rated to IP65.

There are no user serviceable parts inside the **PVD100**. If the unit does not function properly, the unit must be returned to Hydrological Services for component repair.

The **PVD100** does not require any calibration or adjustments. The **PVD100** is self-calibrating and will perform this operation whenever the unit is turned on and whenever CALIBRT is selected via the menu, or whenever a start measurement command (“S”) is received through the serial communications interface.



## 5. Specifications

<i>Bluetooth</i> <sup>®</sup>	Class 2 / Output power 2.5mW (4dBm) Compliant <i>Bluetooth</i> <sup>®</sup> Spec V1.1 Up to 10m (30ft) range (operating at 2.4GHz)
Communications	RS232 Port (Tx, Rx) @ 19200 baud 8/N/1
Connections	2 x Banana plug sockets (Meter input) 1 x DB9 female socket (RS232 + filtered meter o/p)
Indicators	8 character x 2 line LCD 1 x Orange LED 1 x Red/Green/Blue LED
Power Source	2 x Internal AA alkaline 1.5V batteries Low battery indication 2.8V
Dimensions	120mm x 80mm x 22mm (L x W x D)
Weight	218 grams (with batteries)
Environmental	-5C to + 50C, Non Condensing, IP65
(Note: 60° = 1 Meter cup width for 6 cups)	
Water Velocity Flow ( <b>absolute maximum</b> ) <sup>(1)</sup>	
(Normal Mode)	Price AA meter - Mag 13.7m/s (45 ft/s) @ 99° to 204° dwell - CatW 6.7m/s (22 ft/s) @ 10° to 62° dwell Pygmy meter - CatW 2.8m/s (9.4ft/s) @ 10° to 62° dwell
(Slow speed mode)	Price AA meter - Mag 0.76m/s (2.5ft/s) @ 54° to 265° dwell - CatW 0.61m/s (2.0ft/s) @ 17° to 70° dwell (2-cup width) 0.33m/s (1.1ft/s) @ 120° dwell Pygmy meter - CatW 0.27m/s (0.9ft/s) @ 17° to 70° dwell (2-cup width) 0.15m/s (0.5ft/s) @ 120° dwell
Water Velocity Flow ( <b>absolute minimum</b> ) – before setting fault detection <sup>(1)</sup>	
(Normal Mode)	Price AA meter - Mag 0.04m/s (0.14ft/s) @ 15° to 210° dwell - CatW 0.03m/s (0.1 ft/s) @ 10° to 90° dwell Pygmy meter - CatW 0.018m/s (0.06ft/s) @ 10° to 90° dwell
(Slow speed mode)	Price AA meter - Mag 0.012m/s(0.04ft/s) @ 10° to 340° dwell - CatW 0.021m/s(0.07ft/s) @ 10° to 170° dwell Pygmy meter - CatW 0.012m/s(0.04ft/s) @ 10° to 90° dwell
Maximum Conductivity	> 50,000 µSiemens ( <i>max velocity ranges must be derated 20%</i> )

**Specifications...** (continued)

Contact time to Fault Detection (**absolute maximum**)

(Normal Mode)	Magnetic Head Contact	11 Seconds
	Cat Whisker Head Contact	7 Seconds
(Slow speed Mode)	Magnetic Head Contact	30 Seconds
	Cat Whisker Head Contact	20 Seconds

Minimum dwell angle for Cat Whisker Head 10°

Signal Output driver pulse (FET open drain O/P) (Fixed width) Normal mode : 100mS, active high to low pulse  
Slow mode : 1 Sec, active high to low pulse

**(1) NOTES: a) Measurements and Computations based on the following Rating Table Equations.**

Price AA Meter:  $V = \frac{2.2048}{T} + 0.0178$  where: V= Velocity  
T = Seconds/rotation

Pygmy Meter:  $V = \frac{0.9604}{T} + 0.0312$

**b) Measurements made with 0 microSiemens conductivity, open air, ambient room temperature.**

**User Serial Interface Program**

Example: 2.3456[n]+0.1234 where: n=number of rotations/second

**First Term:** 2.3456

**Second Term:** 0.1234

**First Term Entry:** Maximum Allowable: 6.5535

**Second Term Entry:** Maximum Allowable: 0.9999

**Range Values:** Maximum Allowable: 9.99

**Note:** Incorrect or unreasonable entries can give unexpected results.

## Appendix A Capturing a Spin Test

The spin test function allows the user to perform a simple spin test of the meter. The **PVD100** outputs a character string representing the meter count and elapse time. Whenever the ‘spin test’ measurement begins, the **PVD100** will output through the serial data port a character string at every contact closure. This character string is of the following format:

```

nxxx,tttt[cr][lf]
n      = preamble for indicating contact closure data
xxx    = number of meter contact closures, transmitted in decimal
           (i.e. 001, 002, 003, etc)
,      = delimiter
tttt   = counts of elapse time measured as 0.00666 second counts
           (150 Hz), transmitted in HEX ASCII (i.e. 0-9,A-F)
[cr]   = carriage return (ASCII ‘0D’)
[lf]   = line feed (ASCII ‘0A’)
    
```

At the end of the spin test, the **PVD100** sends a final data string that displays the total number of counts and total time all shown in decimal notation. This format makes it easy to copy the final total number of counts and total elapse time information onto a form. Total time is given in seconds and displays the time to a tenth of a second. The format is shown below.

```

dxxx,ttt.t[cr][lf]
d      = preamble for indicating spin measurement data in decimal
xxx    = number of meter contact closures, transmitted in decimal
           (i.e. 001, 002, 003, etc)
,      = delimiter
ttt.t  = total seconds of elapse time displayed to a tenth of a second
[cr]   = carriage return (ASCII ‘0D’)
[lf]   = line feed (ASCII ‘0A’)
    
```

Shown below is an example of both formats, as they would be displayed using the *HyperTerminal* program.

```

N                ← Perform ‘Spin Test’
n000,0000        ← First contact closure
n001,0013
n002,0027
n003,003A
.
.
.
n162,427A
n163,4607        ← Final contact closure
n163,4736        ← Data string when “Stop Spin” executed
d163,121.4       ← Final meter counts and time (in seconds)
A                ← PVD100 initialization completed
    
```

The following information details some specifics about each format, specifically the limitations and alternate characters that may be presented.

- 1) The maximum time that can be displayed, during the measurement, is 'FFFF<sub>16</sub>'. If the measurement continues beyond the maximum data form available, the count 'rolls over' and begins from '0'. When this occurs, the delimiter character ',' is replaced by the '>' character to indicate the rollover condition. When the data is transferred to a spreadsheet, the character, '>', can be easily detected and used to add '65535' (= FFFF<sub>16</sub>) to the elapse time tally. No further change in the delimiter character occurs if the accumulating time continues to further rollover.
- 2) The maximum time that can be displayed as given by the final data string is 436.4 seconds as displayed (FFFF<sub>16</sub> x 0.00666 seconds). This equates to 7 minutes and 16.4 seconds. If the accumulating time continues during the measurement (as discussed above), the final count tally will reflect a calculated value rolled over and beginning from '0'. If this occurs, the delimiter character ',' is replaced by the '>' character to indicate a rollover. To determine the total accumulated time from the roll over condition, simply add 436.4 seconds to the total number displayed.
- 3) The maximum number of measured meter contact closures (clicks) is 999. If the accumulating contact closures continues beyond the maximum data form, the count 'rolls over' and the most significant digit position number is replaced by the colon (':') character. If the count continues, other characters will replace the most significant digit position number. Meter counts should not exceed 999, however a detection scheme is provided if such an occurrence happens.

The "Spin Test" has three subcommands as follows:

- S – Start spin measurement.
- A – Stop spin measurement, transmit final results, then quit.
- I – Abort or quit the "Spin Test" function. No final data is transmitted.

The "Spin Test" is performed in the following manner (through the serial interface) :

1. Before entering the "Spin Test" function, select the type of meter, i.e. Cat Whisker Head, or Magnetic Head Meter. Also enable or disable the buzzer.
2. Press "N" on the computer keyboard to enter the "Spin Test". The **COUNT** LED will become illuminated. The **OPERATING STATUS** indicator will illuminate *green* if the meter is selected for a Magnetic Head and *red* if Cat Whisker Head is selected. The **PVD100** echoes with 'N'.
3. Depress the letter "S" on the computer keyboard or press the SELECT button on the **PVD100**. The **OPERATING STATUS** indicator will turn off.
4. When the meter is spun, the **OPERATING STATUS** indicator will blink when a contact closure is detected.
5. The **PVD100** will output through the serial port a character string (as described

previously) every time there is a meter contact closure. At the first contact closure, the **PVD100** outputs the first contact closure as the start of the measurement. The number of meter contact closures begins with “zero” and the counts of elapsed time begins with “zero.” Contact closures and counts of elapsed time will begin to increment following every contact closure until the “A” command is sent or the SELECT button is pressed. The **PVD100** then sends the final data string (in decimal) followed by the **PVD100** reinitializing. The character ‘A’ is sent when the **PVD100** completes a calibration cycle, as it initializes.

Sending the ‘I’ command anytime before or during the test aborts (or quits) the “Spin Test” function. The **PVD100** sends the character ‘A’ to acknowledge exiting. When the **PVD100** exits, the **PVD100** reinitializes with a calibration. When the calibration has been completed, the **PVD100** sends the character ‘A’ again, and then goes to normal operation mode.

### Capturing a “Spin Test” file

“Spin test” transmitted data can be saved by using the options in the *HyperTerminal* program. *HyperTerminal* is a program that can be found on most computers in the ‘Accessories’ folder listed in the Programs list on the desktop. Within *HyperTerminal* and before spinning the meter, select “Capture Text” found in the Windows label “Transfer” tab. When the “Capture Text” tab is clicked, Windows will ask for a file name. The file name extension will be “.txt”. Select a file name, then click “Start” to save the screen results. After completing the spin test, select “Capture Text” again under the “Transfer” tab. Click “Stop”. The file will be saved under the file name given. The file can be opened using Windows “NotePad” or “WordPad” and can be easily imported into *Excel* for analysis.

To better align the data being displayed, the **PVD100** will respond to the Carriage Return key,  $\text{CR} \rightarrow$ . Entering a  $\text{CR} \rightarrow$ , the **PVD100** will send a  $\text{CR} \rightarrow$  followed by a Line Feed,  $\text{LF} \downarrow$ . This will cause the display cursor to return to the left most position on the display and move down the page by one line position.

Use the following steps to import a text file into *Excel*. This procedure uses Microsoft *Excel 2000*.

1. Open up *Excel* for Windows.
2. Under the ‘Data’ tab, select ‘Get External Data’.
3. Within ‘Get External Data’, select ‘Import Text File’.
4. Select the location of the text file and click ‘Import’.
5. The ‘Text Import Wizard’ pops up with the ‘Delimited’ radio button on. Also, a portion of the actual text file is shown at the bottom of the window.
6. Click up the ‘Start import at row:’ tab to start at row 2.
7. Click ‘Next’ at the bottom to go to Step 2 of the Wizard.

8. In the 'Delimiters' window,
  - a) deselect 'Tab',
  - b) select 'Comma',
  - c) select 'Other', then type 'n' in the box next to 'Other'.

The text file preview should show a vertical line separating the meter counts column data and the time data column.

9. Click 'Next', this will bring you to Step 3 of the Wizard.
10. In Step 3 window, click 'Do not import column (skip)' in the 'Column data format' window. This will show 'Skip' in the column 1 heading.
11. Click on column 3 (where the Time data is shown in HEX-ASCII) and change in the 'Column data format' window from 'General' to 'Text'.
12. In the 'Data Preview' window, the columns should show the following selections on the column heading:
  - a) 'Skip' for column 1
  - b) 'General' for column 2—Current meter counts
  - c) 'Text' for column 3—Time
13. Click 'Finish', and then click 'OK' to import data into the existing worksheet.
14. Save the workbook under a file name.
15. Shown below is an example of an imported 'Spin Test' file.

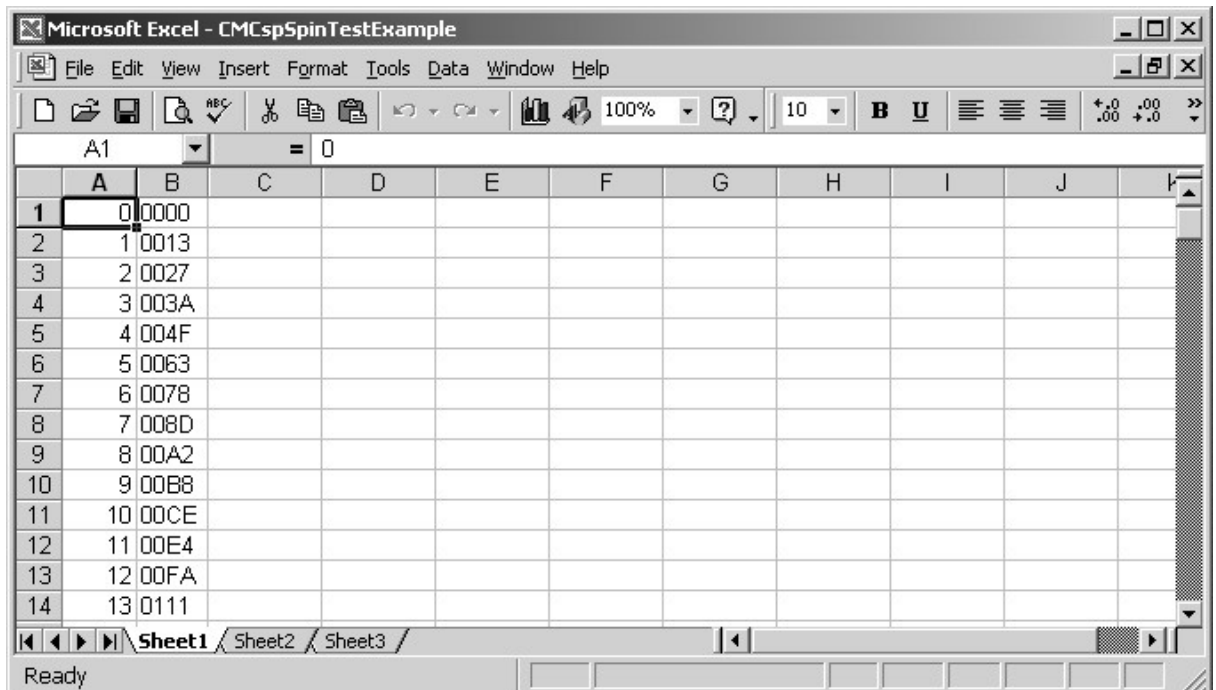

Shown in the figure below is an example of a graph showing the response of a current meter created from data in a "Spin Test" file.



## Appendix B Measuring Meter Dwell

The meter dwell measurement function performs a measure of the contact time in relation to a single rotation of the meter. For the cat whisker contact, it is the measure of the cat whisker contact time on the cam lobe. The resulting measurement is called “dwell”. Dwell is expressed in terms of degrees and for a cat whisker contact; the contact time should be adjusted to be the width of a single cup. This adjustment results in the dwell angle of 60° for a meter with 6 cups and represents optimum performance. The magnetic contact meter (Mag Head) requires no adjustment and therefore measuring the meter dwell angle does not apply but can be performed. When a meter dwell measurement is performed, the **PVD100** takes three measurements and displays the result on the LCD after each measurement, as shown.

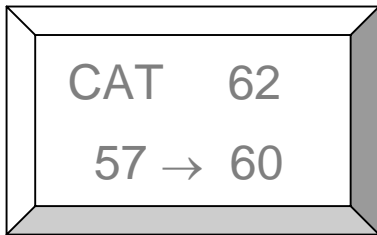

The “Dwell Angle” can be computed by using the following simple formula:

$$\text{Dwell Angle} = \frac{(\text{Contact time}) \times 360}{(\text{Total Time})}$$

The contact time and total time shown above in the formula are expressed in terms of the number of samples measured at a sample rate of 1200 Hz as it is measured by the **PVD100**. A high sample rate is used to reflect a more accurate measure of the contact time and total time measured. The repeatability and variability in measuring the dwell is directly related to mechanical factors such as the condition of the pivot bearings, and the cat whisker wire contact surface and cam lobe. Wide variations in readings reflect conditions that may require further inspection of the meter and its mechanical parts. Some variation in readings is acceptable and represents proper adjustment; however there should be no more than a 10% difference between all the readings. Optimal setting is near 60° (a single meter cup width). High conductivity of >25,000 micro Siemens can affect the operating performance of the **PVD100** and should a current meter be required to operate in high conductivity water, a lower dwell angle setting should be used. A setting of not less than 20° for higher velocities (>0.65 m/sec or 2 ft/sec) is suggested.

## Appendix C Serial Port Echo Command

The **PVD100** has a special serial port character echo command that can be used to echo characters or short strings appearing through the serial port. The command can be used to 'see' what characters are being transmitted to the **PVD100**. This command can be useful to software application developers. To invoke the command, simply send the single ASCII character '~'. On a laptop keyboard, this character is located on the numbers key row and is the left most character key in the row. The character is a shift key character and the 'shift' key must be used to send the character. This echo character command acts like a switch which turns *On* character echo or turns *Off* character echo. When '*character echo*' is turned *On*, any character received through the serial interface is echo'd back through the port and any character sent will **not** be interpreted as a function or operating command to the **PVD100**.

Shown below is a simple pictorial of the Serial Port function of the **PVD100**. Using **Bluetooth**<sup>®</sup> and an additional serial port device connected to the hardware port of the **PVD100**, can assist developers in their applications and 'seeing' what commands are sent to the **PVD100**.

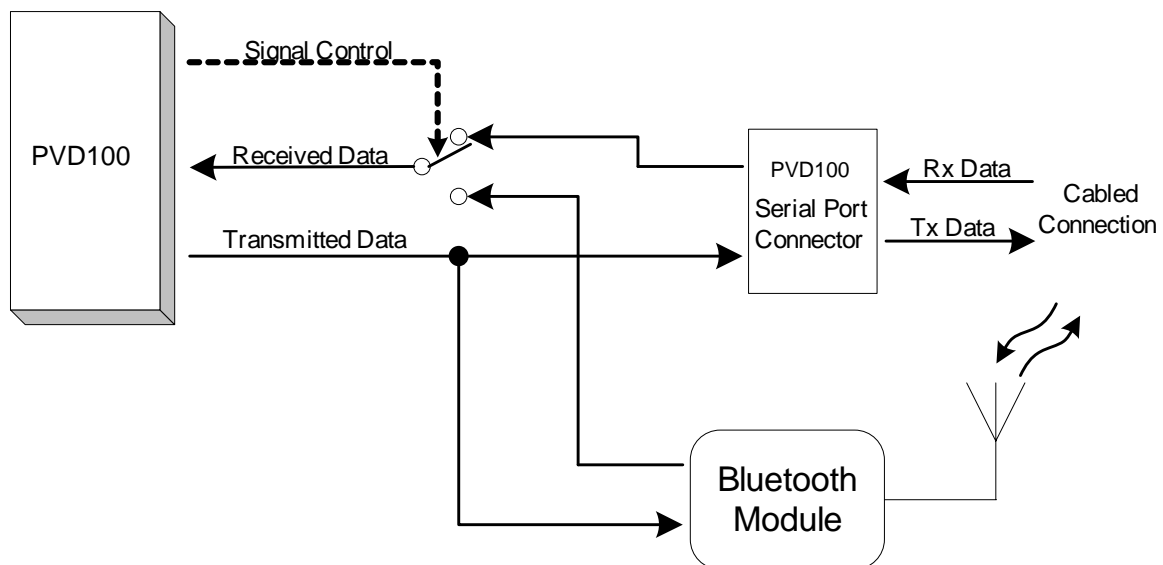

# Appendix D Example Calibration Certificate

HYDROLOGICAL SERVICES PTY. LTD., AUSTRALIA

CERTIFICATE OF CALIBRATION Date: 27/4/06

Current Meter Model: xxxxxx  
Fan No. 1  
Diameter: 125mm  
Type of Support:  
Method of Calibration: Average Value Equation

Serial No. 06-999  
Serial No. 06-123  
Pitch: 0.25m

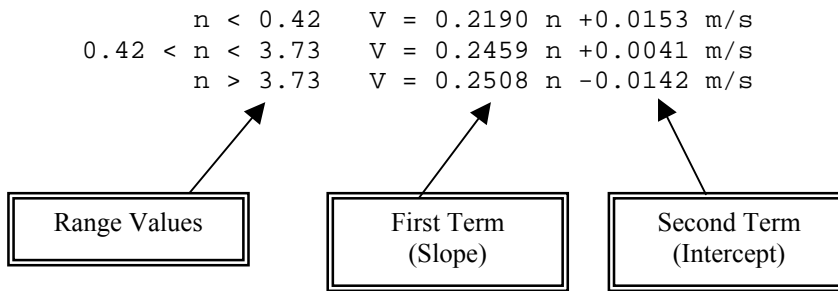

Starting Velocity = 0.025 m/s  
Maximum Velocity = 5.000 m/s

Note: 'n' denotes the number of revolutions of the propeller per second  
'V' is the water velocity in meters per second.

Date: 27/4/06

INSPECTED: \_\_\_\_\_

Fadi Gemayel  
(Mechatronics Engineer)

The above meter has been calibrated in accordance with AS 3778.6.3-1992. This standard is identical with and has been reproduced from ISO 3455:1976.  
The clause below has been printed with the permission of Standards Australia from AS 3778.6.1-1992. This standard is identical with and has been reproduced from ISO 2537:1988. Clause 7.6 Recalibration. Meters shall be recalibrated whenever their performance is suspect. In practice for individually rated meters, recalibration is sometimes carried out at yearly intervals or after 300 hours of use, whichever is the shorter.

D127.08.00